

### APPLICATION

General use : Pulp production, water, water treatment, waste water, chemical industry (powdery or crystallizing products), wine-producing, pulverized products (cement work, pneumatic transport, stocking).

### GENERAL CHARACTERISTICS

Function ON/OFF or regulation.  
Wafer threaded mounting ISO PN10.  
Unidirectional tightness, direction indication thanks to the arrow on the body. Small retention zone: the gate is guided in the body and has little clearance.  
Gland assembly : packing and O-ring (same material as seat joint) to assure the elasticity and decrease the operating torque. Small head loss.  
Possibility to regulate thick fluids with the adaptation of a diaphragm ring .

### CONSTRUCTION

11	1	Electric actuator		AUMA
10**	1	Support ring	Stainless steel 316	DIN : X5CrNiMo18 10 ASTM : A 182 AISI 316 BS : 316 S16
9**	1	Gasket	EPDM	
8	1	O-ring	EPDM	
7	1	Packing gland	Stainless steel	
6	1	Nut support	Painted steel	
5*	2	Support plate	Steel + epoxy	
4	1	Stem	Stainless steel 13%Cr	
3	1	Knife gate	Stainless steel X5CrNi 18-10	DIN : X5CrNiMo18 10 ASTM : A 182 AISI 316 BS : 316 S16
2	2	Packing	PTFE	
1	1	Body	Stainless steel GX5CrNiMo 19-11-2	DIN : G-X6CrNiMo 18 10 ASTM : A 351 grade CF8M BS : 316 C16
<b>Pos.</b>	<b>Qty.</b>	<b>Description</b>	<b>Material</b>	

\* Pre-shaped parts up to DN 300.

\*\*Missing parts on metal/metal tightness.

### DIMENSIONS

DN	Actuator type	A	B	C	D	E	F	G	Ø V	H	Ø K	n	Ø M	Weight (kg)	
50	2"	SA07.2	40	383	124	83	249	265	237	160	578	125	4	4-M16	27
65	2 1/2"	SA07.2	40	408	139	83	249	265	237	160	603	145	4	4-M16	29
80	3"	SA07.2	50	433	154	83	249	265	237	160	628	160	8	4-M16	30
100	4"	SA07.2	50	478	174	83	249	265	237	160	673	180	8	4-M16	31
125	5"	SA07.6	50	516	189	93	249	265	237	160	711	210	8	4-M16	38
150	6"	SA07.6	60	567	220	93	249	265	237	160	762	240	8	4-M20	42
200	8"	SA07.6	60	686	275	108	249	265	237	160	881	295	8	4-M20	57
250	10"	SA07.6	70	778	326	108	249	265	237	160	973	350	12	8-M20	76
300	12"	SA10.2	70	887	380	108	254	282	247	200	1082	400	12	8-M20	86
350	14"	SA10.2	96	990	438	290	254	282	247	200	1185	460	16	10-M20	137
400	16"	SA10.2	100	1100	494	290	254	282	247	200	1295	515	16	10-M24	167
450	18"	SA14.2	106	1225	547	290	329	384	285	315	1430	565	20	14-M24	231
500	20"	SA14.2	110	1335	613	290	329	384	285	315	1540	620	20	14-M24	266
600	24"	SA14.2	110	1539	716	290	329	384	285	315	1744	725	20	14-M27	310

### WORKING CONDITIONS

Maximum working pressure : DN 50-250 : 10 bar  
DN 300-450 : 7 bar  
DN 500-600 : 4 bar

Maximum temperature : -10°C / +130°C (Standard tightness)

Others material on request (If marked)	Maximum temperature	
Metal / metal	T max : -10°C / +130°C.	<input type="checkbox"/>
White Nitril	T max : -10°C / +80°C.	<input type="checkbox"/>
EPDM	T max : -10°C / +130°C.	<input type="checkbox"/>
Silicone	T max : -10°C / +170°C.	<input type="checkbox"/>
FPM (Type Viton®)	T max : -10°C / +170°C.	<input type="checkbox"/>
PTFE	T max : +4°C / +170°C.	<input type="checkbox"/>
CSM (Type Hypalon®)	T max : +4°C / +80°C.	<input type="checkbox"/>

### PRODUCT REFERENCE

REFERENCES	Electric actuator type
<input type="checkbox"/> VG 6400-U04	AUMA 400V 3 PH
<input type="checkbox"/> VG 6400-U14	AUMA 230V 3 PH
<input type="checkbox"/> .....	.....

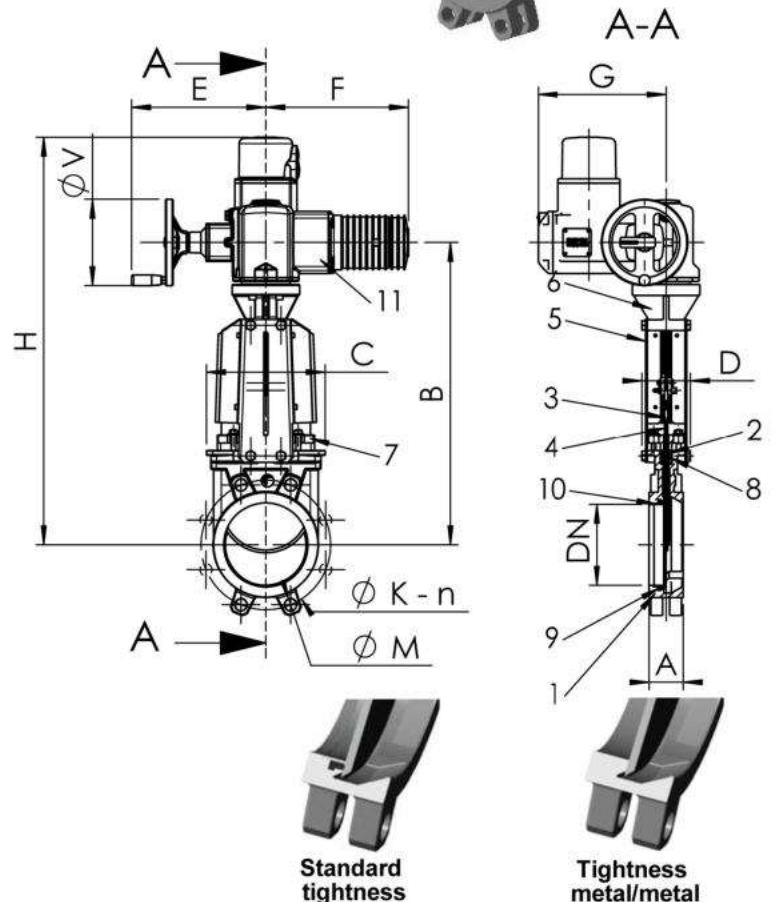

### STANDARDS

Manufacture according to the requirements of the European directive 2014/68/UE «Equipments under pressure» : modulate H. Test procedures are established according to standard EN 12266-1, DIN 3230, BS 5154 and ISO 5208. Connections according to standard EN 1092-2 and DIN 2501 : ISO PN10.