

### APPLICATION

General use : This gate is particularly adapted in paper mill, in the exit of pulp, for the recovery of the old paper where the product is mixed with numerous impurities (ex: staples).

### GENERAL CHARACTERISTICS

- Range : from DN 50 to DN 700.
- Bidirectional gate, with two seat gaskets.
- Longer body in two parts assembled by bolts.
- The gate is longer and its lower part rests out of the body, which requires a second system of gland packing.
- The gate contains a hole, which assures:
  - in opened position, a complete passage of the fluid without retention zone.
  - in closed position, the complete obturation.
- No retention zone: interesting in load or unloading of chemical device (dryer, reactor...).
- Valve tightness even in difficult conditions. No accumulation of product in the bottom of gate evacuation gorge.

### CONSTRUCTION

14	2	Lateral hood	Stainless steel	
13	1	Down hood	Stainless steel	
12	1	Pneumatic actuator	Aluminium	
11	1	Position indicator	Stainless steel 304	
10	1	Actuator stem	Stainless steel	
9*	2	Support plate	Steel + epoxy	
8	2	Packing gland	Aluminium	
7	1	Knife gate	X5CrNi 18-10	DIN : X5CrNi18 10 ASTM : A 182 AISI 304 BS : 1449-2 304 S15
6	2	Gasket	Nitril	
5	2	Support ring	Stainless steel 316	DIN : X5CrNiMo18 10 ASTM : A 182 AISI 316 BS : 970 316 S16
4	2	O-ring	Nitril	
3	4	Packing	Tallowed cotton	
2	1	Second body	Cast iron EN-GJL-250	DIN : GG25 ASTM : A48 class 40B BS : 1452 Grade 250
1	1	Body	Cats iron EN-GJL-250	DIN : GG25 ASTM : A48 class 40B BS : 1452 Grade 250
Pos.	Qty.	Description	Material	

### DIMENSIONS

DN		A	B	C	D	OF	OP	H	OK	n x M	Weight (Kg)
mm	inch										
50	2"	40	246	244	150	1/4"	80	412	125	4 x M16	10
65	2 1/2"	40	264	291	168	1/4"	80	458	145	4 x M16	12
80	3"	50	295	333	184	1/4"	80	502	160	8 x M16	18
100	4"	50	335	383	205	1/4"	100	562	180	8 x M16	24
125	5"	50	375	443	220	1/4"	125	635	210	8 x M16	31
150	6"	60	423	512	240	1/4"	125	718	240	8 x M20	39
200	8"	60	528	652	295	1/4"	160	885	295	8 x M20	67
250	10"	70	627	781	355	1/4"	200	1042	350	12 x M20	126
300	12"	70	702	938	410	1/4"	200	1164	400	12 x M20	138
350	14"	96	835	1043	NC	3/8"	250	1362	460	16 x M20	200
400	16"	100	945	1168	NC	3/8"	250	1542	515	16 x M24	281
450	18"	106	1040	1296	NC	1/2"	250	1677	565	20 x M24	427
500	20"	110	1150	1454	NC	1/2"	300	1842	620	20 x M24	540
600	24"	110	1354	1706	NC	1/2"	300	2147	725	20 x M27	609
700	28"	110	1540	1981	NC	1/2"	350	2542	840	24 x M27	1054



Standard assembling



Strengthened assembling

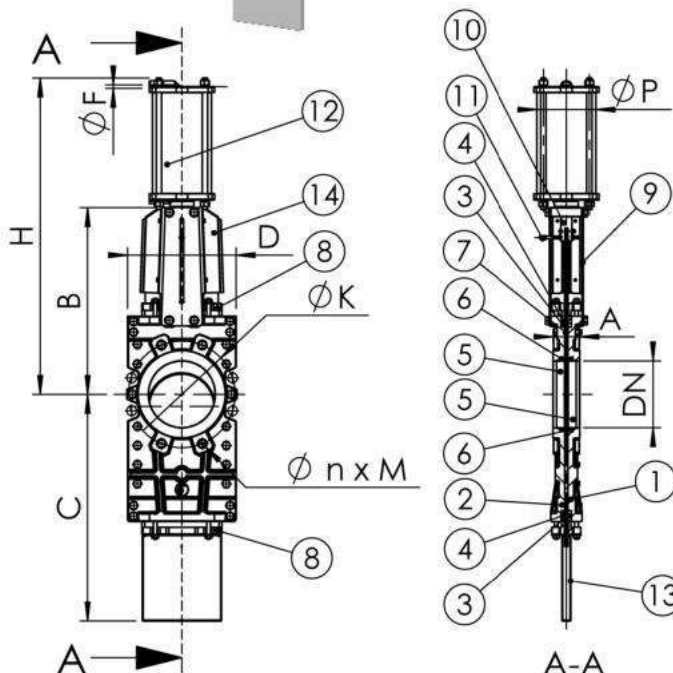

\* Pre-sharped parts up to DN 300.

### WORKING CONDITIONS

Maximum working pressure :

DN 50-250	: 10 bar
DN 300-400	: 6 bar
DN 450-600	: 3.5 bar
DN 700	: 2.5 bar

Maximum temperature : +80 °C

### STANDARDS

Manufacture according to the requirements of the European directive 2014/68/UE «Equipments under pressure» : modulate H.

Test procedures are established according to standards EN 12266-1, DIN 3230, BS 5154 and ISO 5208.

Raised face in accordance to standard EN 1092-2.

Face to face according to standard TECOFI.

Wafer type ISO PN10 according to standard EN 1092-2.