

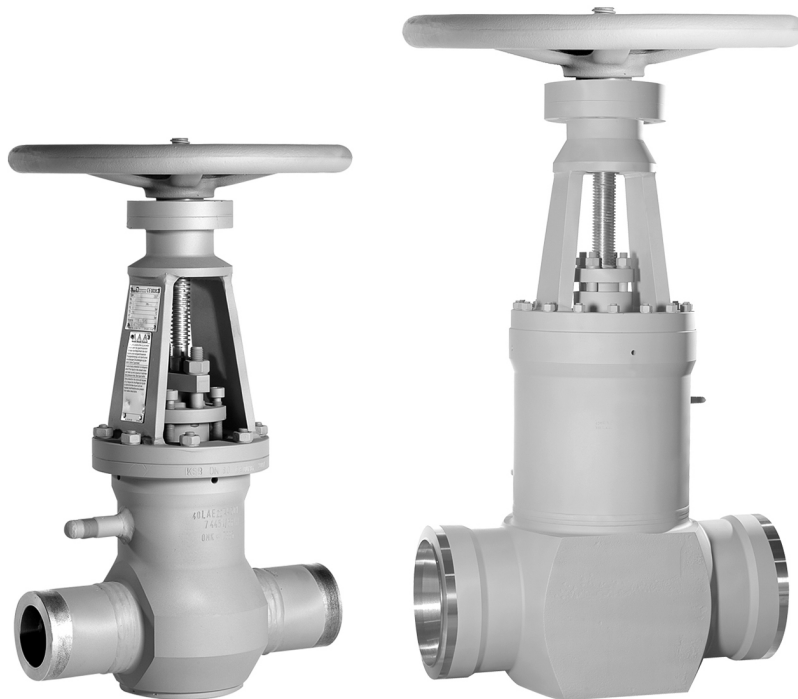

Gate Valve

ZTS

Type Series Booklet



Legal information/Copyright

Type Series Booklet ZTS

All rights reserved. The contents provided herein must neither be distributed, copied, reproduced, edited or processed for any other purpose, nor otherwise transmitted, published or made available to a third party without the manufacturer's express written consent.

Subject to technical modification without prior notice.

© KSB SE & Co. KGaA, Frankenthal 2025-07-28

Contents

Gate Valves	4
Gate Valves to DIN/EN in Pressure Seal Design	4
ZTS	4
Main applications.....	4
Fluids handled	4
Operating data	4
Valve body materials.....	4
Design details	4
Product benefits.....	5
Product information	5
Related documents	5
Purchase order specifications.....	5
Pressure/temperature ratings.....	6
Materials	7
Variants	8
Dimensions and weights.....	12

Gate Valves

Gate Valves to DIN/EN in Pressure Seal Design

ZTS

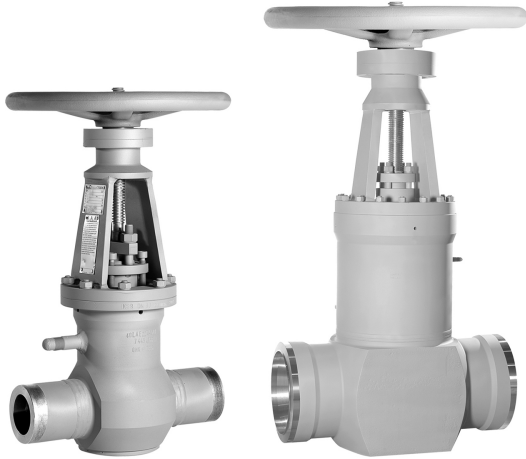

Main applications

- Fossil-fuelled power stations
- Process engineering
- Boiler feed applications
- Boiler recirculation
- Chemical industry
- Petrochemical industry
- Sugar industry
- Paper industry / pulp industry
- Nuclear power stations

Fluids handled

- Water
- Steam
- Other non-aggressive fluids such as gas or oil on request.

Operating data

Table 1: Operating properties

Characteristic	Value
Design pressure [bar]	~ 600
Nominal size	DN 50 - 800
Max. permissible pressure [bar]	~ 600
Min. permissible temperature [°C]	≥ -10
Max. permissible temperature [°C]	≤ +650

Selection as per pressure/temperature ratings (⇒ Page 6)

Valve body materials

Table 2: Overview of available materials

Material	Material number	Temperature limit
P 250 GH	1.0460	≤ 450 °C
15 NiCuMoNb 5	1.6368	≤ 450 °C
16 Mo 3	1.5415	≤ 530 °C
13 CrMo 4-5	1.7335	≤ 550 °C
10 CrMo 9-10/ 11 CrMo 9-10	1.7380/ 1.7383	≤ 580 °C
X 10 CrMoVNb 9-1	1.4903	≤ 650 °C
X 10 CrWMoVNb 9-2	1.4901	≤ 650 °C

Other materials on request.

Design details

Design

- Body made of forged steel
- Pressure seal design
- Non-rotating stem
- Split wedge
- Yoke head suitable for mounting electric and pneumatic actuators (DIN ISO 5210)
- Seat/disc interface made of wear-resistant and corrosion-proof Stellite

Variants

- Flanged ends
- Bypass
- Drain branch
- Parallel discs
- Pressure relief connections (3-branch system)
- Pressure relief hole in seat ring
- Hard-faced back seat
- Lantern ring in gland packing
- Disc spring supported threaded bush
- Packing combination for high-temperature applications
- Pressure seal joint ring capped with stainless steel
- Position indicator
- Limit switch(es)
- Spur gear
- Bevel gear
- Electric actuators
- Pneumatic actuators
- Actuating bush for remote actuation
- Threaded bush free from non-ferrous metals
- Locking device
- Inspections to technical codes such as AD2000 or to customer specification

Product benefits

- Additional features ensure safe sealing to atmosphere:
 - Pressure seal design: The higher the pressure in the gate valve body, the tighter the bonnet joint. Metal-capped pure graphite gasket. Very low risk of leakage, particularly at high pressures and temperatures. Compact design.
 - Graphite gland packing with packing end rings, protected against oxidation by metal caps.
- Robust body made of billet-forged steel.
 - Very dense, homogenous and fine-grained microstructure. Extremely robust material able to withstand high stresses.
 - Ideal for very high pressures and temperatures.
 - Compared with cast bodies no risk of porosity and shrinkage cavities. Excellent weldability.
- Additional features ensure safe sealing to atmosphere:
 - Pressure seal bonnet. Low risk of leakage, particularly at high pressures and temperatures.
 - Graphite gland packing with packing end rings.
- Reliable, tight shut-off and service-friendly design
 - Wedge holder with flexibly mounted split wedge. Precise alignment of wedge discs with body; wedge discs are easy to replace.
 - Actuating moments are absorbed by the wedge holder guided in the body. No additional loads on the wedge discs and the seat/disc interface.
 - Standard DIN/ISO top flange at the yoke head simplifies actuator mounting.
- Additional safety and blow-out protection by standard back seat.
- Long service life and high functional reliability
 - Stop nut as standard. Limited wedge action prevents jamming in closed position and ensures reliable opening of the gate valve even in the event of temperature transients.
 - Of the gland packing due to non-rotating stem with burnished shank.
 - Threaded bush runs in ball bearings for smooth actuation.
 - Hard-faced seat/disc interface made of wear-resistant and corrosion-proof 17 % chrome steel or Stellite.

Product information

Product information as per Regulation No. 1907/2006 (REACH)

For information as per European chemicals regulation (EC) No. 1907/2006 (REACH) see <https://www.ksb.com/en-global/company/corporate-responsibility/reach>.

Product information as per Directive 2014/34/EU (ATEX)

The valves do not have a potential internal source of ignition and can be used in potentially explosive atmospheres, Group II, category 2 (zones 1+21) and category 3 (zone 2+22) to ATEX 2014/34/EU.

Product information as per European Pressure Equipment Directive 2014/68/EU (PED)

The valves satisfy the safety requirements of Annex I of the European Pressure Equipment Directive 2014/68/EU (PED) for fluids in Groups 1 and 2.

Related documents

Table 3: Information/documents

Document	Reference number
ZRS type series booklet (swing check valves with pressure seal cover)	7278.1
UGS/UGSV/UGSVA type series booklet (body pressure relief valve)	7300.1
Operating manual	0570.81

Purchase order specifications

Please specify the following information in all enquiries or purchase orders:

1. Type
2. Nominal pressure
3. Nominal size
4. Design pressure
5. Differential pressure
6. Design temperature
7. Material
8. Fluid handled
9. Flow rate
10. Pipe connection
11. Variants
12. Reference number
13. Pressure relief
14. Installation position
15. Actuation method

Always indicate the original serial number and the year of construction when ordering spare parts.

Pressure/temperature ratings

Subseries B¹⁾

Table 4: Permissible operating pressure [bar]²⁾

Material	Subseries ³⁾	[°C]																	
		20	300	350	400	425	450	475	500	510	520	530	540	550	560	570	580	590	600
16 Mo 3 1.5415	B	100	86	81	75	72	69	57	44	-	-	-	-	-	-	-	-	-	-
13 CrMo 4-5 1.7335	B	100	100	95	90	87	84	74	65	55	45	37	-	-	-	-	-	-	-
10 CrMo 9-10 1.7380/ 11 CrMo 9-10 1.7383	B	100	100	98	93	90	88	76	64	56	49	43	37	32	-	-	-	-	-
X10CrMoVNb9-1 1.4903	B	100	100	100	100	100	100	100	100	100	100	96	87	79	71	64	57	50	45

Subseries C, D, E and F

Table 5: Permissible operating pressure [bar]^{2/4)}

Material	Subseries ³⁾	[°C]																										
		20	100	150	200	250	300	350	400	425	450	475	500	510	520	530	540	550	560	570	580	590	600	610	620	630	640	650
P 250 GH 1.0460	C	212	202	181	161	141	126	105	85	76	66	-	-	-	-	-	-	-	-	-	-	-	-	-	-	-	-	-
	D	323	308	277	246	215	192	161	130	115	100	-	-	-	-	-	-	-	-	-	-	-	-	-	-	-	-	-
	E	426	407	366	325	284	254	213	172	152	132	-	-	-	-	-	-	-	-	-	-	-	-	-	-	-	-	-
	F	521	496	446	397	347	310	260	210	186	160	-	-	-	-	-	-	-	-	-	-	-	-	-	-	-	-	-
15NiCuMoNb5 1.6368	C	367	367	367	367	367	356	341	327	314	242	-	-	-	-	-	-	-	-	-	-	-	-	-	-	-	-	
	CS ⁵⁾	445	445	445	445	445	430	415	400	380	300	-	-	-	-	-	-	-	-	-	-	-	-	-	-	-	-	
	D ⁶⁾	558	558	558	558	558	539	518	498	476	374	-	-	-	-	-	-	-	-	-	-	-	-	-	-	-	-	
	E	738	738	738	738	738	711	685	658	629	495	-	-	-	-	-	-	-	-	-	-	-	-	-	-	-	-	
16 Mo 3 1.5415	C	268	237	214	192	177	151	147	141	140	136	134	94	66	52	42	-	-	-	-	-	-	-	-	-	-	-	-
	D	408	361	326	292	269	231	223	215	211	207	205	143	100	79	63	-	-	-	-	-	-	-	-	-	-	-	-
	E	539	478	432	386	356	304	294	284	279	275	269	189	132	104	83	-	-	-	-	-	-	-	-	-	-	-	-
	F	657	583	527	471	434	372	359	347	341	335	329	231	162	128	102	-	-	-	-	-	-	-	-	-	-	-	-
13 CrMo 4-5 1.7335	C	268	243	228	213	202	187	177	167	162	157	155	138	118	95	79	61	49	-	-	-	-	-	-	-	-	-	-
	D	408	369	346	323	308	284	269	254	246	238	235	211	178	145	119	93	75	-	-	-	-	-	-	-	-	-	-
	E	539	488	457	427	407	376	355	335	325	315	310	277	236	191	158	124	100	-	-	-	-	-	-	-	-	-	-
	F	657	596	558	521	496	459	434	409	397	385	378	341	288	233	193	151	121	-	-	-	-	-	-	-	-	-	-
10 CrMo 9-10 1.7380/ 11 CrMo 9-10 1.7383	C	268	248	232	217	213	202	187	177	173	167	162	136	119	104	91	79	69	58	51	-	-	-	-	-	-	-	-
	D	408	377	354	331	323	308	284	269	262	254	246	207	181	158	138	119	104	89	78	-	-	-	-	-	-	-	-
	E	539	498	467	437	427	407	376	355	345	335	325	275	239	210	183	158	138	117	103	-	-	-	-	-	-	-	-
	F	657	608	570	533	521	496	459	434	422	409	397	335	292	255	223	193	168	144	126	-	-	-	-	-	-	-	-
X10CrMoVNb9-1 1.4903	C	-	-	-	-	-	-	-	-	-	-	-	-	-	245	225	204	185	166	148	131	116	102	89	78	67	59	50
	D	-	-	-	-	-	-	-	-	-	-	-	-	-	324	296	270	244	214	195	174	154	135	117	103	87	77	67
	E	-	-	-	-	-	-	-	-	-	-	-	-	-	470	429	391	353	316	283	251	221	197	170	148	126	112	96
	F	-	-	-	-	-	-	-	-	-	-	-	-	-	514	472	428	387	347	311	275	244	215	186	162	139	122	105
X10CrWMoVNb9-2 1.4901	C	-	-	-	-	-	-	-	-	-	-	-	-	-	-	-	-	-	-	134	120	107	94	82	71	61	53	
	D	-	-	-	-	-	-	-	-	-	-	-	-	-	-	-	-	-	-	201	180	160	142	123	106	92	79	
	E	-	-	-	-	-	-	-	-	-	-	-	-	-	-	-	-	-	-	262	234	208	184	160	138	120	103	
	F	-	-	-	-	-	-	-	-	-	-	-	-	-	-	-	-	-	-	314	281	250	221	192	166	144	124	

- 1 DN 350-800
- 2 The valves are suitable for temperatures down to -10 °C.
- 3 The subseries defines the maximum operating pressure possible for the respective temperature. The gate valve is designed and marked for the actual design data specified in the purchase order.
- 4 The test pressure is defined in accordance with the provisions of the technical codes PED 2014/68/EU, DIN EN 12516-2 and EN 12266-1.
- 5 Weights, dimensions and differential pressures on request.
- 6 Special design subseries CD on request. Depending on the nominal size, permissible operating pressures up to the maximum pressure and temperature of subseries D are possible (however, with restrictions regarding the differential pressure for subseries D).

Materials

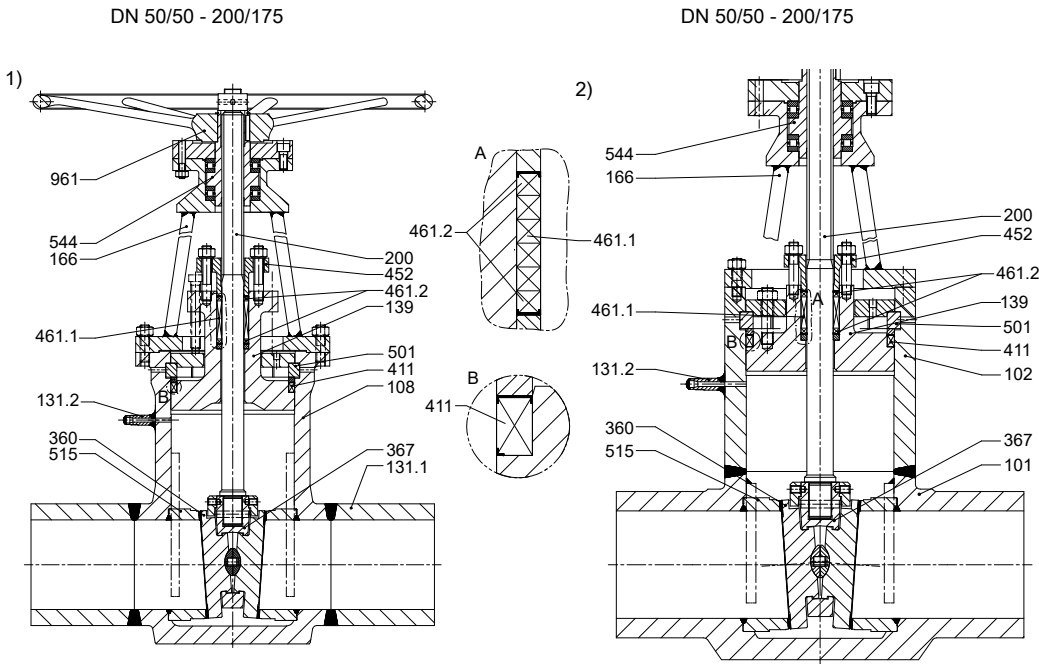

Fig. 1: Sectional drawings; ZTS 1) With connection branch extensions 2) Without connection branch extensions

Table 6: Parts list

Part No.	Description	Materials for operating temperatures [°C] up to					
		450	530	550	570	600	650
101	Lower body section	P 250 GH	15NiCuMoNb5	16 Mo 3	13 CrMo 4-5	10 CrMo 9-10	X10CrMoVNb 9-1
102	Upper body section	1.0460	1.6368	1.5415	1.7335	1.7380/ 11 CrMo 9-10	1.4903
108	Main body					1.7383	X10CrWMoVNb 9-2
131.1	Connection branch					1.7383	1.4901
139	Bonnet	10 CrMo 9-10		10 CrMo 9-10			
501 ⁷⁾	Segmental ring	1.7380/ 11 CrMo 9-10		1.7380/ 11 CrMo 9-10			
360 ⁷⁾	Wedge discs Hard-faced with Stellite 6	1.7383		1.7383			
368 ⁷⁾	Parallel discs Hard-faced with Stellite 6						
515	Seat ring Hard-faced with Stellite 6	13 CrMo 4-5		13 CrMo 4-5		10 CrMo 9-10	
		1.7335		1.7335		1.7380/ 11 CrMo 9-10	
						1.7383	
131.2	Connection branch	P 250 GH	13 CrMo 4-5				11 CrMo 9-10
		1.0460	1.7335				1.7383
							X10CrMoVNb 9-1
							1.4903
166	Yoke	13 CrMo 4-5					11 CrMo 9-10
		1.7335					1.7383
							X10CrMoVNb 9-1
							1.4903
200 ⁷⁾	Stem	X39CrMo17-1					X22CrMoV11-1
		1.4122					1.4923
		X22CrMoV11-1					X5NiCrTi2615
		1.4923					1.4980
367 ⁷⁾	Disc/wedge holder	13 CrMo 4-5	15NiCuMoNb5	10 CrMo 9-10			X10CrMoVNb 9-1
		1.7335	1.6368	1.7380/ 11 CrMo 9-10			1.4903
				1.7383			
411 ⁷⁾	Joint ring	Pure graphite, capped with stainless steel					
452	Gland follower	13 CrMo 4-5				10 CrMo 9-10	
		1.7335				1.7380/ 11 CrMo 9-10	
						1.7383	

7451.1/22-EN

7 Recommended spare parts

Part No.	Description	Materials for operating temperatures [°C] up to					
		450	530	550	570	600	650
461 ⁷⁾	Gland packing	Pure graphite/stainless steel capped packing end rings					
544 ⁷⁾	Threaded bush	Copper base alloys					
961	Handwheel	Steel					

Variants

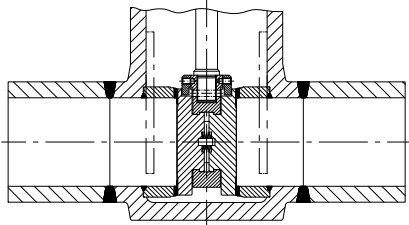

Parallel discs
(type GTS)

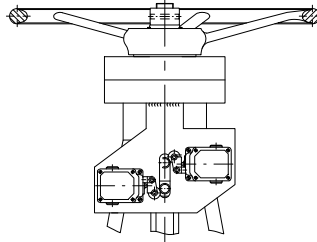

Position indicator with
position switch

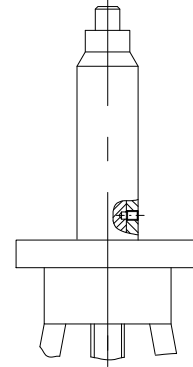

Actuating bush

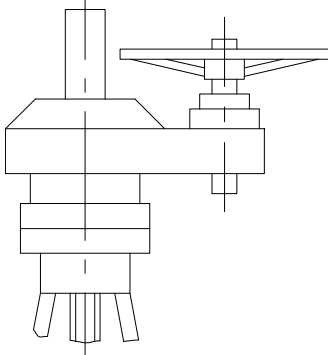

Spur gear with
handwheel

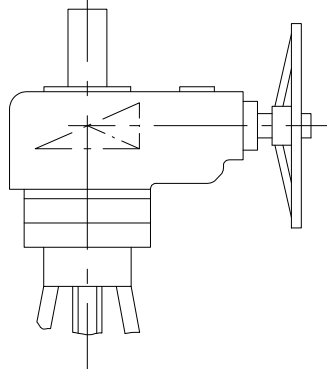

Bevel gear with
handwheel

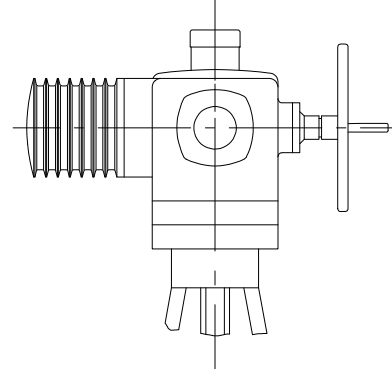

Electric actuator

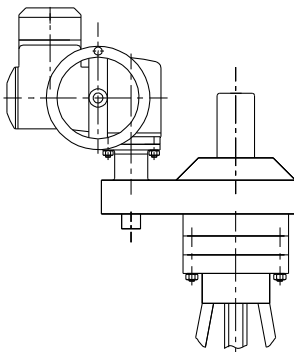

Electric actuator with spur
gear

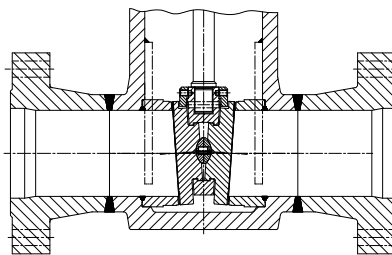

Model with flanged

Model with connection branch extensions
(DN 200/200 - 500/450)

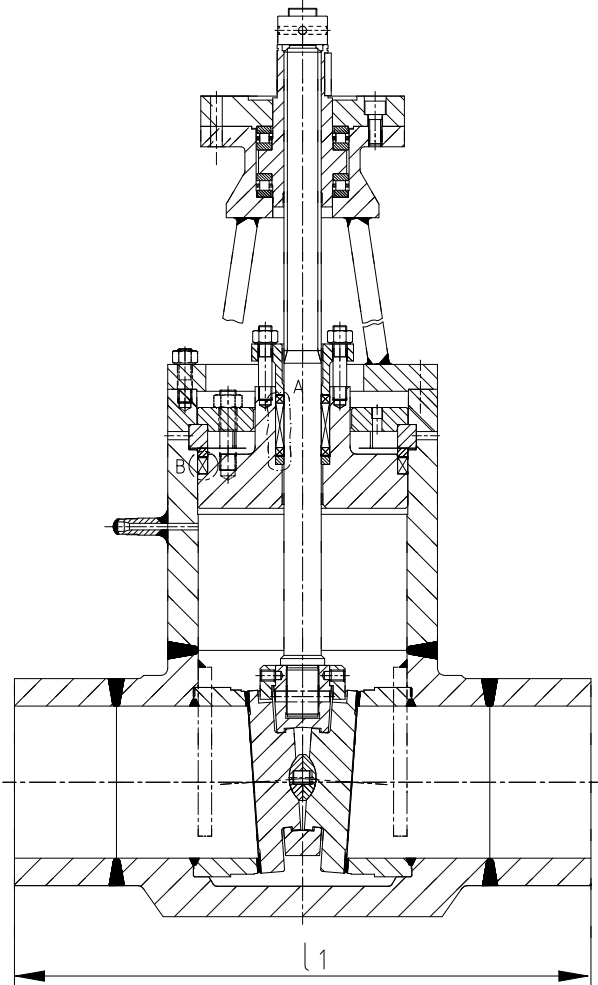

Fig. 2: ZTS with connection branch extensions

Face-to-face lengths and weights

Table 7: Dimensions and weights

Nominal size / seat diameter	Face-to-face length l ₁				Weights with handwheel ⁸⁾			
	Subseries							
	C	D	E	F	C	D	E	F
	[mm]	[mm]	[mm]	[mm]	[kg]	[kg]	[kg]	[kg]
200/200	750	950	950	1050	435	830	1175	1550
250/200	900	1150	1150	1150	470	920	1330	1675
250/250	900	1150	1150	1150	740	1380	2075	2740
300/250	1050	1350	1350	1350	820	1555	2250	2965
300/300	1050	1350	1350	1350	1295	2320	3365	4350
350/300	1200	1550	1550	1550	1420	2615	On request	
350/350	1200	1550	1550	1550	1865	3445		
400/350	1350	1750	1750	1750	2035	3890		
400/400	1350	1750	1750	1750	2700	4835		
450/400	1500	1950	1950	1950	2975	5510		
450/450	1500	1950	1950	1950	3450	6420		
500/450	1650	2150	2150	2150	3835	-		

7451.1/22-EN

8 Weights may vary with special designs/variants.

Body pressure relief valve

i Also refer to type series booklet 7300.1.

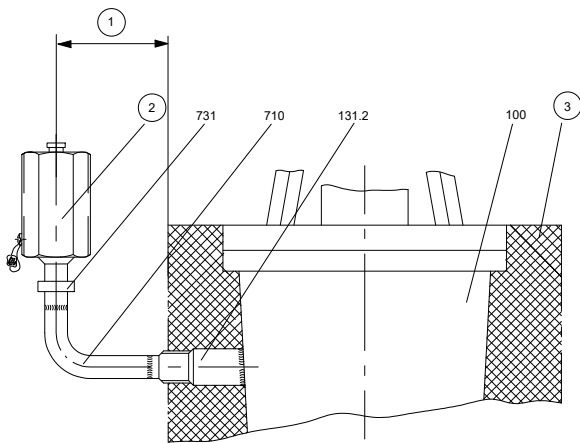

Fig. 3: UGS/UGSV body pressure relief valve on gate valve in pressure seal design

①	200 mm minimum distance	②	Body pressure relief valve for both flow directions
③	Insulation	100	Body
131.2	Connection branch	710	Pipe, not included in KSB's scope of supply
731	Pipe union		

A body pressure relief valve is necessary if, with the gate valve closed, there is a danger of the liquid trapped inside the valve body heating up and causing an unacceptable pressure increase inside the valve. A warning sign is affixed to the yoke arm near the name plate.

All gate valves with pressure seal bonnet are factory-supplied with a closed connection branch 131.2 with connection dimensions $\varnothing 22 \text{ mm} / \varnothing 14.1 \text{ mm}$ (or 12.3 mm), suitable for a pipe of $\varnothing 21.3 \text{ mm} \times 3.6 \text{ mm}$ (or 4.5 mm).

Bypass

When the pressure difference specified below between the operating pressure upstream and the backpressure downstream of the valve is exceeded, the gate valves must be provided with a bypass. If a bypass is necessary or requested for other reasons, a NORI 320/ NORI 500 globe valve as per type series booklet 7640.1/7641.1, DN 15 (for gate valve seat diameters up to and incl. 150 mm) or DN 25 (for gate valve diameter from 175 mm), is fitted in the bypass line as standard (larger nominal sizes on request).

Table 8: Differential pressure [bar]

Subseries	Seat diameter S						
	/50-/175	/200	/250	/300	/350	/400	/450
C	255	255	255	255	240	240	205
D	365	365	365	330	330	275	275
E	475	440	385	275	275	220	220
F	585	330	275	220	220	200	200

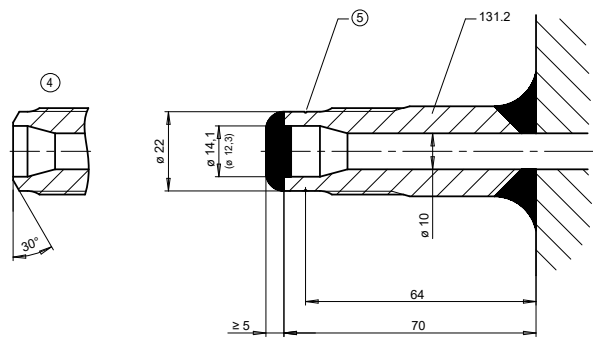
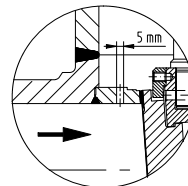

Fig. 4: Closed connection branch for body pressure relief valve

④	Welding groove	⑤	When connecting to pipe 710, cut here and bevel the face to obtain a welding groove.
131.2	Connection branch		

When ordering please state whether a pressure relief valve is to be provided, or whether excess pressure is to be released via a bypass and/or a relief hole in the inlet-side seat ring 515. In those cases, the gate valves can be used for one flow direction only.



Pressure relief hole in inlet-side seat ring

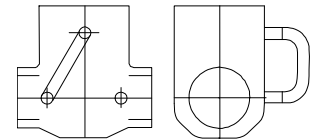

To be connected on site, depending on flow direction

i The pressure relief valve must not be welded directly to connection branch 131.2 but must be connected to it via an intermediate pipe 710 in a vertical, upright position outside the insulating material. The minimum distance to the insulation is 200 mm.

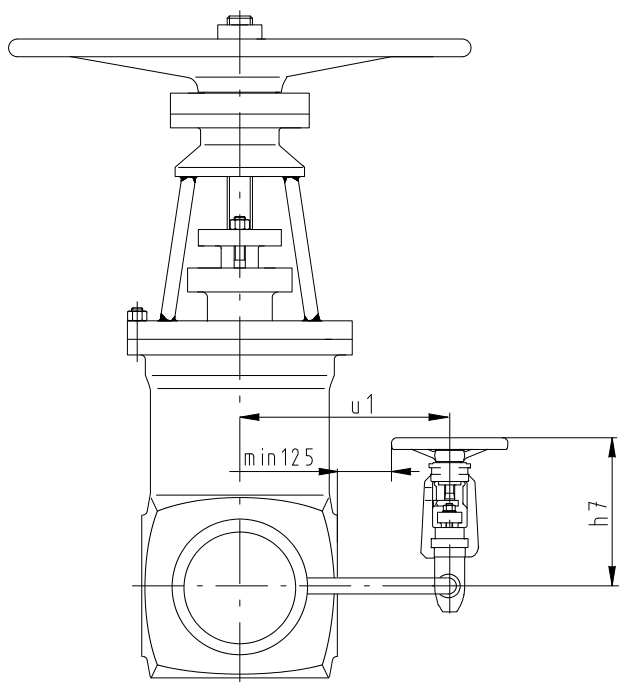

Model with handwheel and bypass with handwheel

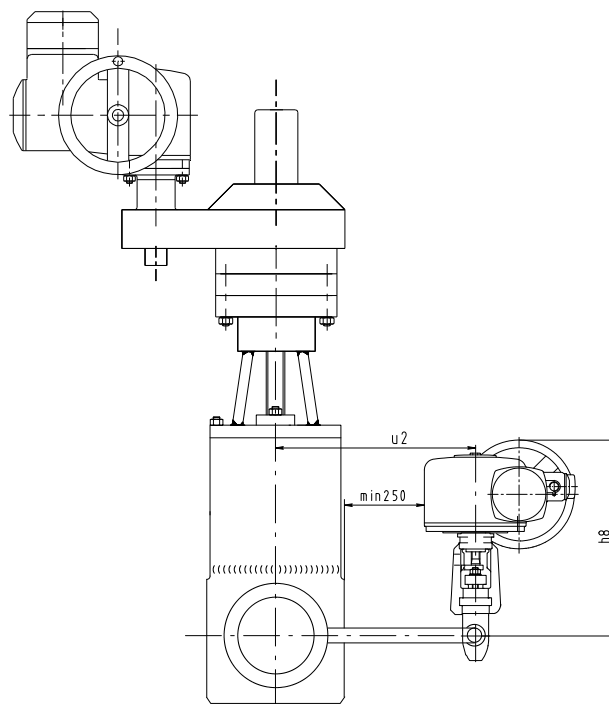

Model with spur gear and bypass with actuator

Bypass dimensions for subseries C and D

Table 9: Dimensions

Seat diameter S	Max. overhang		Height	
	u ₁	u ₂	h ₇	h ₈
	[mm]	[mm]	[mm]	[mm]
/50	315	425	240	570
/65	330	440	240	570
/80	340	450	240	570
/100	360	470	240	570
/125	395	505	240	570
/150	420	530	240	570

Dimensions for subseries E and F on request

Seat diameter S	Max. overhang		Height	
	u ₁	u ₂	h ₇	h ₈
	[mm]	[mm]	[mm]	[mm]
/175	455	565	255	570
/200	500	695	255	570
/250	560	755	255	570
/300	600	830	255	570
/350	600	830	255	570
/400	600	830	255	570
/450	705	935	255	570

Dimensions and weights

Dimensions and weights of subseries B

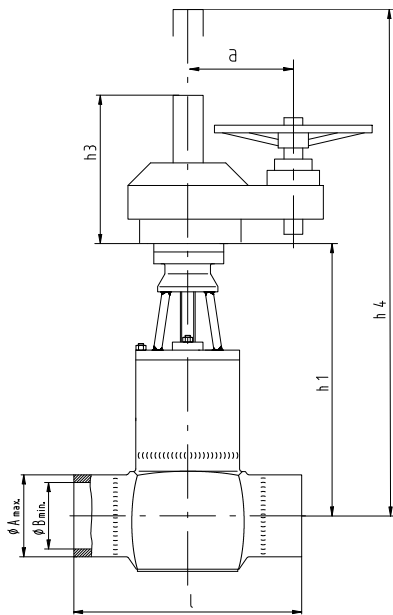

Fig. 5: ≥ DN 600/500

Table 10: Dimensions and weights

DN ()	I	Butt weld ends, unmachined		Centre-to-top heights			Overhang	[kg]
		ØA _{max.}	ØB _{min.}	h ₁	h ₃	h ₄ ⁹⁾	a	
		[mm]	[mm]	[mm]	[mm]	[mm]	[mm]	
600/550	1350	660	500	2200	830	3580	410/445	On request
700/650	1550	770	600	2300	930	3830	410/445	
800/750	1750	870	700	2570	1080	4400	410/445	

Mating dimensions as per standard

Dimensions of butt weld ends and weld groove form to customer's specification, but only within dimensions A_{max.} and B_{min.}.
Special dimensions on request.

⁹ Vertical clearance for removal

Dimensions and weights of subseries C and D

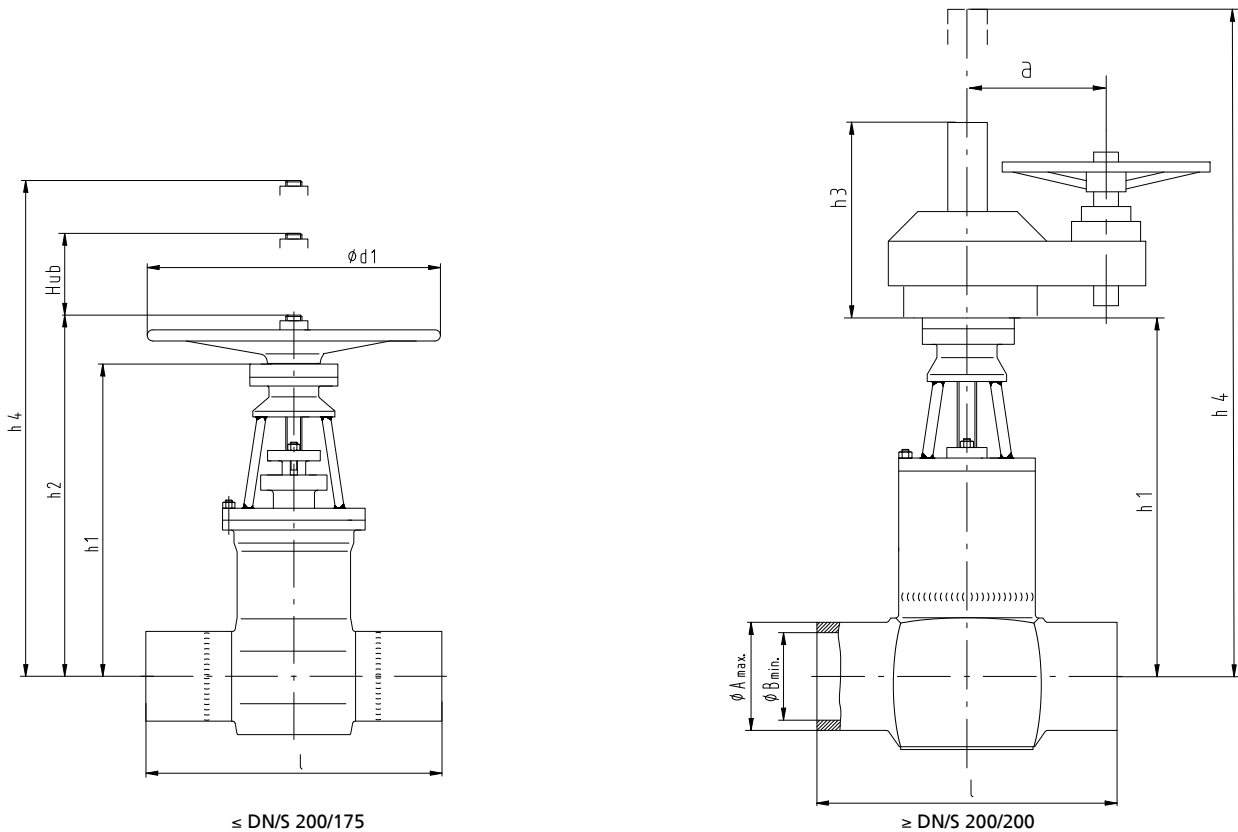

Fig. 6: ZTS, subseries C and D

Table 11: Dimensions and weights

DN / S ⁽¹⁰⁾	I		Butt weld ends, unmachined		h ₁	h ₂	h ₃	h ₄ ⁽¹¹⁾	a	d ₁	Travel		[kg] ⁽¹²⁾									
			ØA _{max.}	ØB _{min.}							C	D	C	D								
	Subseries														C	D	C	D	C	D		
	C	D	C	D	C, D	C	D	C	D	C	D	C	D	C	D	C	D	C	D	C	D	
	[mm]	[mm]	[mm]	[mm]	[mm]	[mm]	[mm]	[mm]	[mm]	[mm]	[mm]	[mm]	[mm]	[mm]	[mm]	[mm]	[mm]	[mm]	[mm]	[mm]	[mm]	[mm]
50/50	300	350	65	70	45	400	475	485	560	145	170	680	810	175	240	315	400	60	60	45	64	
65/50	360	425	85	90	45	400	475	485	560	145	170	680	810	175	240	315	400	60	60	49	66	
65/65	360	425	85	104	60	480	475	565	560	195	170	790	815	175	240	315	400	70	75	55	79	
80/65	390	470	102	130	60	480	475	565	560	195	170	790	815	175	240	315	400	70	75	57	81	
80/80	390	470	102	115	70	505	545	600	640	195	220	850	940	175	240	400	500	85	87	73	118	
100/80	450	550	120	140	70	505	545	600	640	195	220	850	940	175	240	400	500	85	87	76	125	
100/100	450	550	120	140	90	620	660	710	760	220	255	1020	1120	240	240/300	400	500	105	109	119	222	
125/100	525	650	145	155	90	620	660	710	760	220	255	1020	1120	240	240/300	400	500	105	109	122	230	
125/125	525	650	155	175	110	655	745	750	855	270	305	1110	1290	240	240/300	500	630	123	136	177	283	
150/125	600	750	180	185	110	655	745	750	855	270	305	1110	1290	240	240/300	500	630	123	136	182	293	
150/150	600	750	180	200	135	790	855	890	970	300	320	1315	1470	240/300	300/360	500	800	147	156	267	431	
175/150	675	850	200	220	135	790	855	890	970	300	320	1315	1470	240/300	300/360	500	800	147	156	277	446	
200/150	750	950	225	250	135	790	855	890	970	300	320	1315	1470	240/300	300/360	500	800	147	156	290	461	
175/175	675	850	220	230	155	810	1030	925	1175	320	400	1425	1780	300/360	300/360	630	1000	176	184	405	615	
200/175	750	950	245	280	155	810	1030	925	1175	320	400	1425	1780	300/360	300/360	630	1000	176	184	415	665	
200/200	700	800	260	295	180	910	1065	1025	1210	370	400	1605	1885	300/360	360/380	800	1000	196	207	430	740	
250/200	700	800	295	340	180	910	1065	1025	1210	370	400	1605	1885	300/360	360/380	800	1000	196	207	435	785	
250/250	850	950	305	365	225	1015	1280	1150	1445	450	450	1870	2700	360/380	360/380	1000	1000	238	250	740	1255	
300/250	850	950	360	410	225	1015	1280	1150	1445	450	450	1870	2700	360/380	360/380	1000	1000	238	250	765	1355	
300/300	950	1150	380	410	275	1350	1525	1515	1740	500	575	2385	2475	360/380	380/410	1000	¹³⁾	295	310	1300	2155	

- 10 Larger nominal sizes on request.
- 11 Vertical clearance for removal
- 12 Weights may vary with special designs/variants.
- 13 Transmission gearing required.

DN / S ⁽¹⁾	I	Butt weld ends, unmachined		h ₁	h ₂	h ₃	h ₄ ⁽¹⁾	a	d ₁	Travel	[kg] ⁽²⁾												
		ØA _{max.}	ØB _{min.}								C	D	C	D	C	D	C	D					
		Subseries																					
		C	D	C	D	C	D	C	D	C	D	C	D	C	D	C	D	C	D	C	D		
		[mm]	[mm]	[mm]	[mm]	[mm]	[mm]	[mm]	[mm]	[mm]	[mm]	[mm]	[mm]	[mm]	[mm]	[mm]	[mm]	[mm]	[mm]	[mm]	[mm]	[kg]	[kg]
350/300	950	1150	410	470	275	1350	1525	1515	1740	500	575	2385	2475	360/380	380/410	1000	⁽³⁾	295	310	1350	2340		
350/350	1050	1350	430	480	320	1475	1625	1640	1875	500	645	2630	2995	360/380	410/445	⁽³⁾	⁽³⁾	345	354	1810	3300		
400/350	1050	1350	460	535	320	1475	1625	1640	1875	500	645	2630	2995	360/380	410/445	⁽³⁾	⁽³⁾	345	354	1900	3600		
400/400	1200	1550	485	565	365	1720	1785	1930	2035	675	745	3055	3300	380/410	410/445	⁽³⁾	⁽³⁾	400	402	2640	4650		
450/400	1200	1550	515	600	365	1720	1785	1930	2035	675	745	3055	3300	380/410	410/445	⁽³⁾	⁽³⁾	400	402	2795	5135		
450/450	1350	1750	530	600	410	1765	2100	1975	2380	675	795	3220	3755	380/410	410/445	⁽³⁾	⁽³⁾	440	453	3360	6185		
500/450	1350	1750	585	600	410	1765	2100	1975	2380	675	795	3220	3755	380/410	410/445	⁽³⁾	⁽³⁾	440	453	3635	6700		

Mating dimensions as per standard

Dimensions of butt weld ends and weld groove form to customer's specification, but only within dimensions A_{max.} and B_{min.}
Special dimensions on request.

Dimensions and weights of subseries E and F

Table 12: Dimensions and weights

DN / S ⁽⁴⁾	I	Butt weld ends, un-machined		h ₁	h ₂	h ₃	h ₄ ⁽⁵⁾	a	d ₁	Travel	[kg] ⁽⁶⁾												
		ØA _{max.}	ØB _{min.}								E	F	E, F	E	F	E, F	E	F					
		Subseries																					
		E	F	E	F	E, F	E	F	E	F	E, F	E	F	E	F	E, F	E	F	E	F			
		[mm]	[mm]	[mm]	[mm]	[mm]	[mm]	[mm]	[mm]	[mm]	[mm]	[mm]	[mm]	[mm]	[mm]	[mm]	[mm]	[mm]	[mm]	[mm]	[mm]	[kg]	[kg]
50/50	350	350	85	85	45	475	475	560	560	170	840	240	400	400	63	80	85						
65/50	425	425	95	95	45	475	475	560	560	170	840	240	400	400	63	82	87						
65/65	425	425	110	110	60	555	555	650	650	220	975	240	500	500	78	120	145						
80/65	470	470	120	120	60	555	555	650	650	220	975	240	500	500	78	123	148						
80/80	470	470	120	130	70	675	675	775	775	220/255	1160	240/300	500	630	91	205	250						
100/80	550	550	130	140	70	675	675	775	775	220/255	1160	240/300	500	630	91	210	255						
100/100	550	550	150	160	90	775	810	885	920	220/255	1380	240/300	630	800	112	285	415						
125/100	650	650	160	180	90	775	810	885	920	220/255	1380	240/300	630	800	112	295	420						
125/125	650	650	185	195	110	875	910	990	1025	305/320	1535	240/300	800	800	140	475	690						
150/125	750	750	195	225	110	875	910	990	1025	305/320	1535	240/300	800	800	140	490	710						
150/150	750	750	225	240	135	965	1000	1110	1145	320/370	1715	360/380	1000	1000	162	750	1000						
175/150	850	850	240	260	135	965	1000	1110	1145	320/370	1715	360/380	1000	1000	162	770	1025						
200/150	950	950	260	290	135	965	1000	1110	1145	320/370	1715	360/380	1000	1000	162	790	1050						
175/175	850	850	250	270	155	980	1050	1125	1195	370/410	1795	360/380	1000	1000	189	1050	1370						
200/175	950	950	260	290	155	980	1050	1125	1195	370/410	1795	360/380	1000	1000	189	1090	1420						
200/200	900	1050	285	300	180	1130	1165	1295	1330	420/460	1990	360/380	1000	1000	210	1160	1550						
250/200	900	1050	350	375	180	1130	1165	1295	1330	420/460	1990	360/380	1000	1000	210	1220	1620						
250/250	1050	1150	350	375	225	1410	1435	1620	1645	460/525	2465	380/410	1000	1000	260	2030	2740						
300/250	1050	1150	425	445	225	1410	1435	1620	1645	460/525	2465	380/410	1000	1000	260	2120	2815						
300/300	1250	1350	425	435	275	1705	1755	1915	1965	510/575	2945	380/410	Transmission gearing required		320	3300	4350						
350/300	1250	1350	500	520	275	1705	1755	1915	1965	510/575	2945	380/410			320	On request							
350/350	1450	1550	500	520	320	1805	1920	2055	2170	625/645	3255	410/445			372								
400/350	1450	1550	565	595	320	1805	1920	2055	2170	625/645	3255	410/445			372								
400/400	1650	1750	565	595	365	1945	2080	2195	2330	725/745	3495	410/445			408								
450/400	1650	1750	640	670	365	1945	2080	2195	2330	725/745	3495	410/445			408								
450/450	1850	1950	640	670	410	2180	2320	2460	2600	845	3900	410/445			456								
500/450	1850	1950	640	670	410	2180	2320	2460	2600	845	3900	410/445			456								

Mating dimensions as per standard

Dimensions of butt weld ends and weld groove form to customer's specification, but only within dimensions A_{max.} and B_{min.}
Special dimensions on request.

- 14 Larger nominal sizes on request.
- 15 Vertical clearance for removal
- 16 Weights may vary with special designs/variants.



KSB SE & Co. KGaA
Bahnhofplatz 1 • 91257 Pegnitz (Germany)
Tel. +49 9241 71-0
www.ksb.com

2025-07-28

7451:1/22-EN