

MOTORI ELETTRICI C.C. A MAGNETI PERMANENTI
PERMANENT MAGNETS D.C. ELECTRIC MOTORS

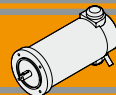

TRANSTECNO TM				CE	
THE MODULAR GEARMOTOR				DC MOTOR	
www.transtecnos.com				24	IP
MODEL	EC600-240	VOLTS	47.2	INSUL.CL.	F
TORQUE(Nm)	2.54	AMPS	3000	DUTY	S2
WATT	800	RPM		P.F.	1
DATE					





	Indice	Index	Pag. Page
	Caratteristiche tecniche	<i>Technical features</i>	12
	Grado di protezione IP	<i>IP enclosures protection indexes</i>	13
	Classe di isolamento termico	<i>Insulation class</i>	13
EC020.120	Caratteristiche	<i>Features</i>	14
EC020.24E	Dimensioni	<i>Dimensions</i>	14
	Prestazioni	<i>Performances</i>	15
EC035.120	Caratteristiche	<i>Features</i>	16
EC035.240	Dimensioni	<i>Dimensions</i>	16
	Prestazioni	<i>Performances</i>	17
EC050.120	Caratteristiche	<i>Features</i>	18
EC050.240	Dimensioni	<i>Dimensions</i>	18
	Prestazioni	<i>Performances</i>	19
EC070.120	Caratteristiche	<i>Features</i>	110
EC070.240	Dimensioni	<i>Dimensions</i>	110
	Prestazioni	<i>Performances</i>	111
EC100.120	Caratteristiche	<i>Features</i>	112
EC100.240	Dimensioni	<i>Dimensions</i>	112
EC100.24E	Prestazioni	<i>Performances</i>	113
EC180.120	Caratteristiche	<i>Features</i>	114
EC180.240	Dimensioni	<i>Dimensions</i>	114
EC180.24E	Prestazioni	<i>Performances</i>	115
EC350.120	Caratteristiche	<i>Features</i>	116
EC350.240	Dimensioni	<i>Dimensions</i>	116
	Prestazioni	<i>Performances</i>	117
EC600.120	Caratteristiche	<i>Features</i>	118
EC600.240	Dimensioni	<i>Dimensions</i>	118
	Prestazioni	<i>Performances</i>	119
	Legenda / Glossario dei grafici	<i>Key / Diagram Glossary</i>	120
	Formule utili	<i>Useful formulas</i>	120

Questa sezione annulla e sostituisce ogni precedente edizione o revisione. Qualora questa sezione non Vi sia giunta in distribuzione controllata, l'aggiornamento dei dati ivi contenuto non è assicurato. **In tal caso la versione più aggiornata è disponibile sul nostro sito internet www.transtecno.com**

This section replaces any previous edition and revision. If you obtained this catalogue other than through controlled distribution channels, the most up to date content is not guaranteed. In this case the latest version is available on our web site www.transtecno.com

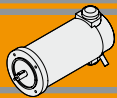

Caratteristiche tecniche

Technical features

Le caratteristiche principali dei motori della serie EC sono:

- Campo magnetico generato da magneti permanenti
- Costruzione tubolare, senza ventilazione
- Disponibili in 5 grandezze: diametro 42, 52, 65, 81, 110 mm
- Alimentazione a bassa tensione, 12 o 24 Vcc
- Potenze disponibili da 30 a 800 W S2
- Elevate coppie di spunto
- Elevate coppie e potenze in dimensioni compatte

The main features of EC motor range are:

- Magnetic field generated by permanent magnets
- Tubular construction, without fan
- Available in 5 sizes: diameter 42, 52, 65, 81, 110 mm
- Low voltage power supply, 12 or 24 Vdc
- Power ratings available from 30 to 800 W S2
- High starting torque
- High torque and output power with compact package

Classe di isolamento termico

Gli avvolgimenti del rotore sono soggetti a surriscaldamento, come pure altre parti del motore. Il grado di isolamento indica la massima temperatura ammissibile oltre la quale l'isolante della matassa e l'isolante di tutte le parti soggette ad elevato riscaldamento perde le caratteristiche di buon isolante, con pericolo di danneggiamento del motore.

Thermal insulation class

The windings of the rotor can overheat just like other parts of the motor too. The degree of insulation indicates the maximum allowable temperature above which the insulation of the windings, as well as that of all the parts which heat up to a high temperature, loses its insulating properties and the motor therefore risks being damaged.

Servizio

Rappresenta la relazione tra il tempo di lavoro ed il tempo di riposo del motore. Servizio continuo (S1) = funzionamento continuo del motore a pieno carico.

Servizio intermittente (S2, S3, etc...) = periodi alternati di lavoro e di riposo tali da raffreddare il motore. Dato un motore, la potenza espressa per servizio continuo è inferiore a quella per servizio intermittente.

Duty cycle

This represents the relationship between the time the motor operates and the time it remains stationary. Continuous operation (S1) = the motor operates non-stop under full load.

Intermittent operation (S2, S3, etc.) = alternating periods of work and rest so that the motor can cool down. The output power for continuous operation is lower than that for intermittent operation.

Fattore di forma

Indica quanta componente spuria alternata è presente nella alimentazione CC del motore. Più alto è il fattore ed inferiore è l'efficienza del motore. Alimentatori ad SCR = F.F 1.40. Alimentazione pura da batteria = FF 1. Alimentazione da transistori (modulazione PWM) = FF 1.05.

Qualitativamente l'andamento della coppia (percentuale) rispetto al fattore di forma è indicato nel grafico seguente:

Form factor

It indicates how much spurious alternating current is present in the D.C. motor power supply. The higher the factor, the lower the motor's efficiency. SCR power supplies = F.F 1.40. Battery supply = FF 1 Transistor supply (PWM modulation) = FF 1.05.

The graph below indicates the torque trend (percentage) in relation to the form factor.

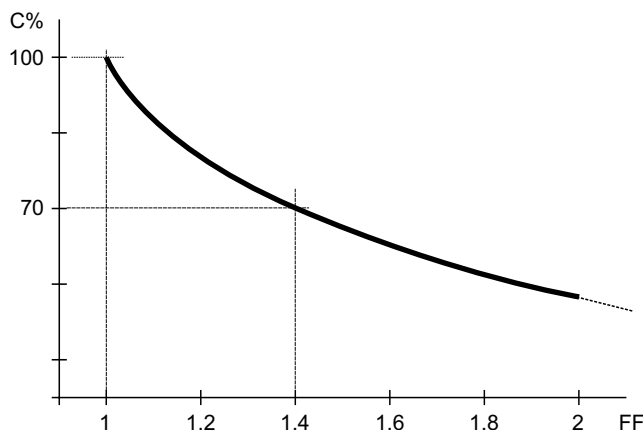

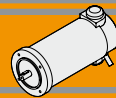

Grado di protezione IP

IP enclosures protection indexes

Indica il grado di isolamento meccanico del corpo motore.

Indicates the degree of mechanical insulation of the motor body.
 1st figure indicating level of protection against the penetration of solid bodies.

1^a cifra protezione alla penetrazione di corpi solidi.

2nd figure: indicating degree to which the motor is waterproof.

2^a cifra protezione contro la penetrazione d'acqua.

0	Non protetto / No protection	0	Non protetto / No protection
1	Protetto da corpi solidi superiori a Ø 50 mm. Protected against solid matters (over Ø 50 mm)	1	Protetto contro la caduta verticale di gocce d'acqua. Protected against drops of water falling vertically
2	Protetto da corpi solidi superiori a Ø 12 mm. Protected against solid matters (over Ø 12 mm)	2	Protetto contro la caduta verticale di gocce d'acqua con inclinazione max di 15° Protected against drops of water falling up to 15°
3	Protetto da corpi solidi superiori a Ø 2,5 mm. Protected against solid matters (over Ø 2,5 mm)	3	Protetto contro la pioggia. Rain proof fixture
4	Protetto da corpi solidi superiori a Ø1 mm. Protected against solid matters (over Ø1 mm)	4	Protetto contro gli spruzzi. Splash proof fixture
5	Protetto contro la polvere Dust proof	5	Protetto contro getti d'acqua Water jet proof
6	Totalmente protetto contro la polvere Fully dust proof	6	Protetto dalle ondate Wave proof
7	N.A.	7	Protetto contro immersione Watertight immersion fixture.
8	N.A.	8	Protetto contro immersione/sommersione prolungata Watertight immersion fixture for a long time.

Classe di isolamento termico

Insulation class

Classe / Class	Δt °C Temp. ambiente: 40°C Ambient temperature: 40°C
A	65°C
B	90°C
F	115°C
H	140°C

Tipi di servizio IEC

IEC duty cycle ratings

S1	Servizio continuo. Funzionamento a carico costante per una durata sufficiente al raggiungimento dell' equilibrio termico.	Continuous duty. The motor works at a constant load for enough time to reach temperature equilibrium
S2	Servizio di durata limitata. Funzionamento a carico costante per una durata inferiore a quella necessaria al raggiungimento dell' equilibrio termico, seguito da un periodo di riposo tale da riportare il motore alla temperatura ambiente.	Short time duty. The motor works at a constant load, but not long enough to reach temperature equilibrium, and the rest periods are long enough for the motor to reach ambient temperature.
S3	Servizio periodico intermittente. Sequenze di cicli identici di marcia e di riposo a carico costante, senza raggiungimento dell' equilibrio termico. La corrente di spunto ha effetti trascurabili sul surriscaldamento del motore.	Intermittent periodic duty. Sequential, identical run and rest cycles with constant load. Temperature equilibrium is never reached. Starting current has little effect on temperature rise.
S4	Servizio periodico intermittente con avviamento. Sequenza di cicli di funzionamento identici di avviamento, marcia e riposo a carico costante, senza raggiungimento dell'equilibrio termico. La corrente di spunto ha effetti sul riscaldamento del motore.	Intermittent periodic duty with starting. Sequential identical start, run and rest cycles with constant load. Temperature equilibrium is not reached, but starting current affects temperature rise.
S5	Servizio periodico intermittente con frenatura elettrica. Sequenza di cicli di funzionamento identici di avviamento, marcia a carico costante, frenatura elettrica e riposo, senza raggiungimento dell'equilibrio termico.	Intermittent periodic duty with electric braking. Sequential, identical cycles of starting, running at constant load, electric braking and rest. Temperature equilibrium is not reached.
S6	Servizio periodico ininterrotto con carico intermittente. Sequenza di cicli di lavoro identici con carico costante e senza carico. Non ci sono periodi di riposo.	Continuous operation with intermittent load. Sequential, identical cycles of running with constant load and running with no load. No rest periods.
S7	Servizio periodico ininterrotto con frenatura elettrica. Sequenza di cicli di funzionamento identici di avviamento, marcia a carico costante e frenatura elettrica, senza periodi di riposo.	Continuous operation with electric braking. Sequential, identical cycles of starting, running at constant load and electric braking. No rest periods.
S8	Servizio periodico ininterrotto con variazioni di carico e di velocità. Sequenza di cicli identici di avviamento, marcia a carico costante e velocità definita, seguiti da marcia a carico costante differente e velocità differente dalla precedente. Non ci sono periodi di riposo.	Continuous operation with periodic changes in load and speed. Sequential, identical, duty cycles of start, run at constant load and given speed, then run at other constant loads and speeds. No rest periods.

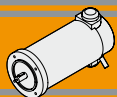

EC020.120 - EC020.24E

Caratteristiche

Features

Costruzione	Tubolare, senza ventilazione
Grandezza	Ø 42 mm
Potenza	30 W S2 (20 W S1)
Magneti	2
Supporti	Cuscinetti a sfera
Fori di montaggio	4
Alimentazione	Bassa tensione, 12 o 24 Vcc
Spazzole	N° 2 di composto grafite-rame
Cavo di alimentazione	Connettori faston (0.8 x 2.8 mm)
Opzioni	Filtro EMC
	Encoder magnetico max. 2 imp/giro, 2 canali Max.

Construction	Tubular, without fan
Size	Ø 42 mm
Power	30 W S2 (20 W S1)
Magnets	2
Bearings	Ball bearing
Mounting holes	4
Power supply	Low voltage, 12 or 24 Vdc
Brushes	2 brushes made of graphite/copper composite
Electric cable	Faston terminals (0.8 x 2.8 mm)
Options	EMC filter
	Magnetic encoder max 2 ppr, Max. 2 channels

Tipo Type	S	Pn [W]	V [V]	I [A]	IC	FF	Mn [Nm]	n ₁ [min ⁻¹]	IP	Kg
EC020.120	S1	20	12	2.6	B	1	0.06	2850	20	0.4
	S2 6'	30		3.5			0.08			
EC020.24E	S1	20	24	1.4			0.06			
	S2 6'	30		1.9			0.08			

Dimensioni

Dimensions

EC020.120

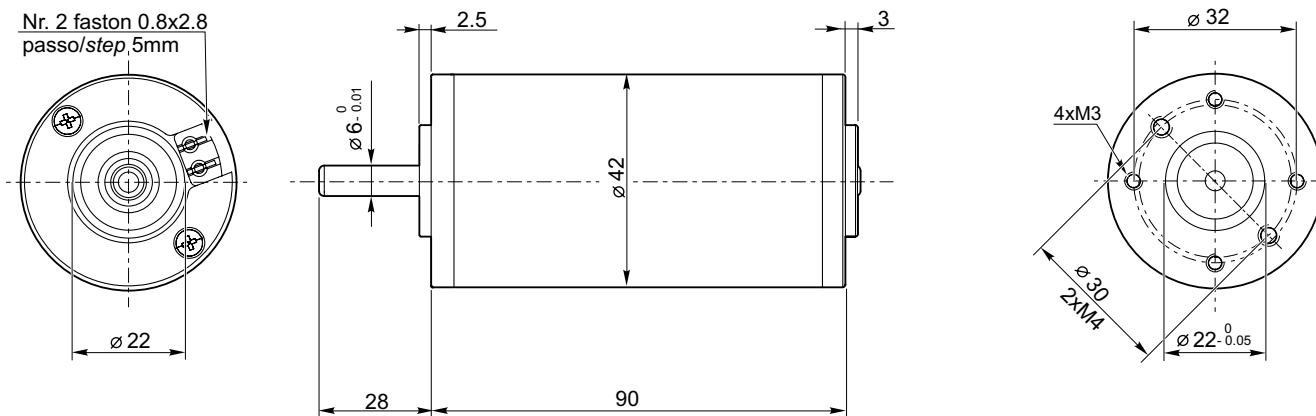

EC020.24E

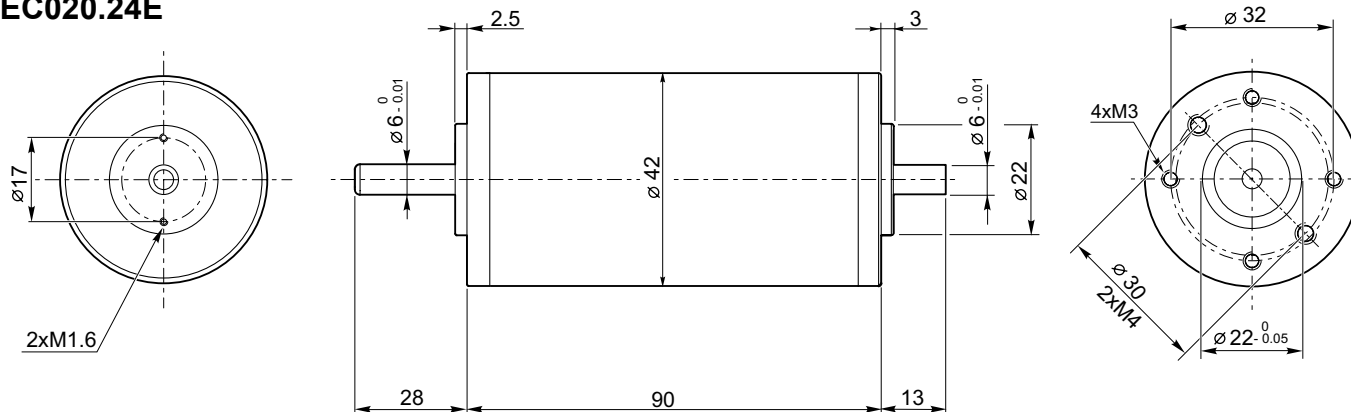

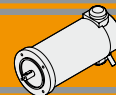

EC020.120 - EC020.24E

Prestazioni

Performances

EC020.120

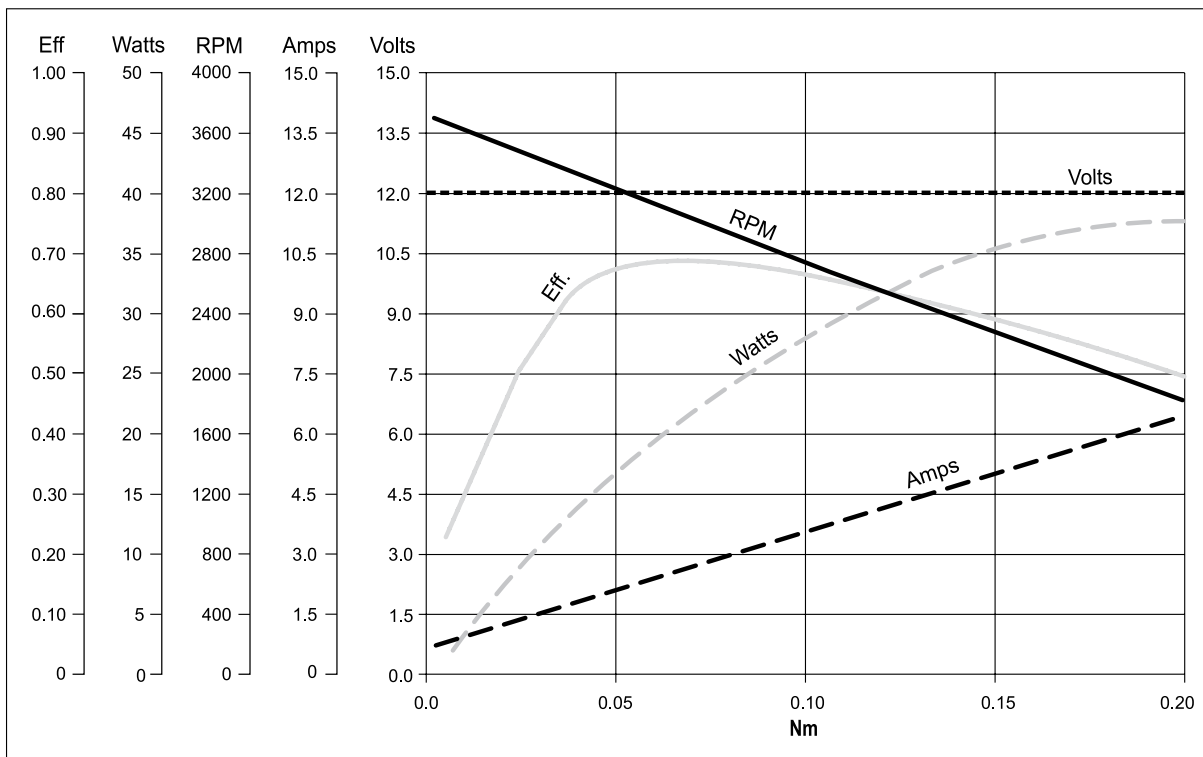

EC020.24E

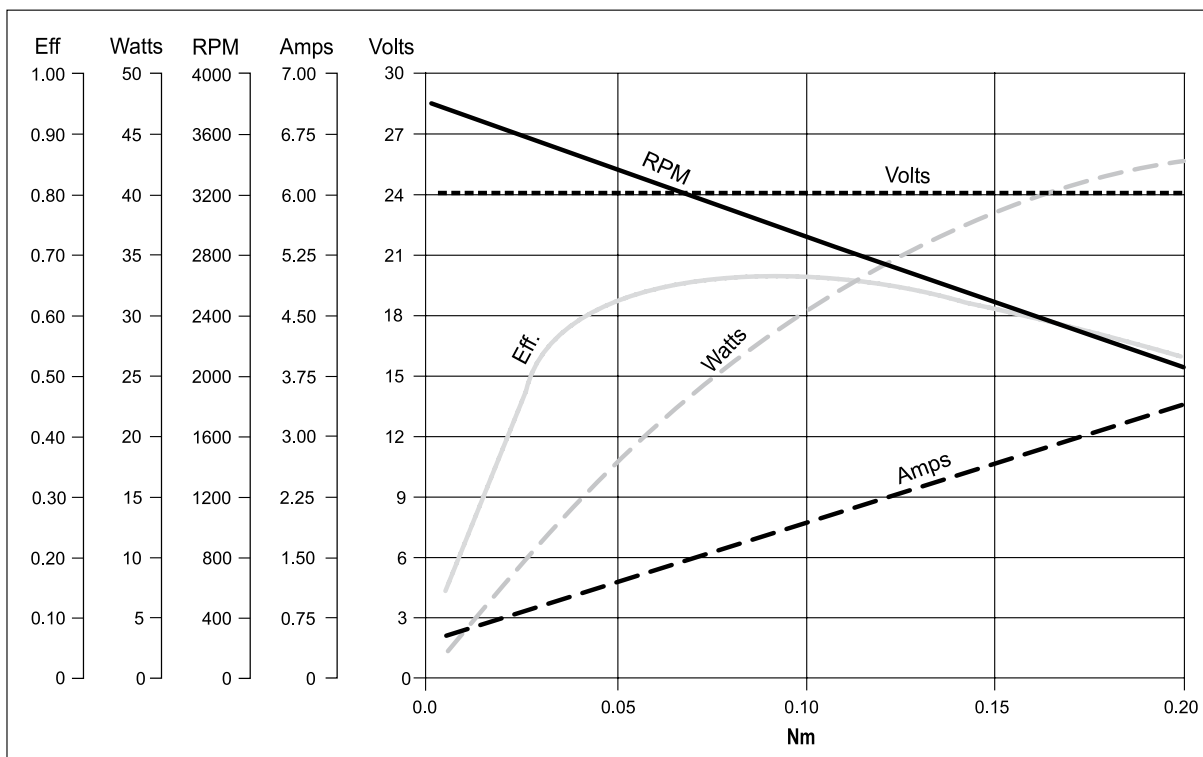

EC

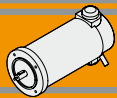

EC035.120 - EC035.240

Caratteristiche

Features

Costruzione	Tubolare, senza ventilazione
Grandezza	Ø 52 mm
Potenza	55 W S2 (35 W S1)
Magneti	2
Supporti	Cuscinetti a sfera
Fori di montaggio	4
Alimentazione	Bassa tensione, 12 o 24 Vcc
Spazzole	N° 2 interne di composto grafite-rame
Cavo di alimentazione	Lunghezza: 200 mm
Opzioni	Encoder magnetico max. 1 imp/giro, max.2 canali

Construction	Tubular, without fan
Size	Ø 52 mm
Power	55 W S2 (35 W S1)
Magnets	2
Bearings	Ball bearings
Mounting holes	4
Power supply	Low voltage, 12 or 24 Vdc
Brushes	2 inside brushes made of graphite/copper composite
Electric cable	Length: 200 mm
Options	Magnetic encoder max 1 ppr, Max. 2 channels

Tipo Type	S	Pn [W]	V [V]	I [A]	IC	FF	Mn [Nm]	n ₁ [min ⁻¹]	IP	Kg
EC035.120	S1	35	12	5.2	F	1	0.11	3000	44	0.8
	S2 9'	55		8.0			0.18			
EC035.240	S1	35	24	2.6	F	1	0.11		44	0.8
	S2 9'	55		4.0			0.18			

Dimensioni

Dimensions

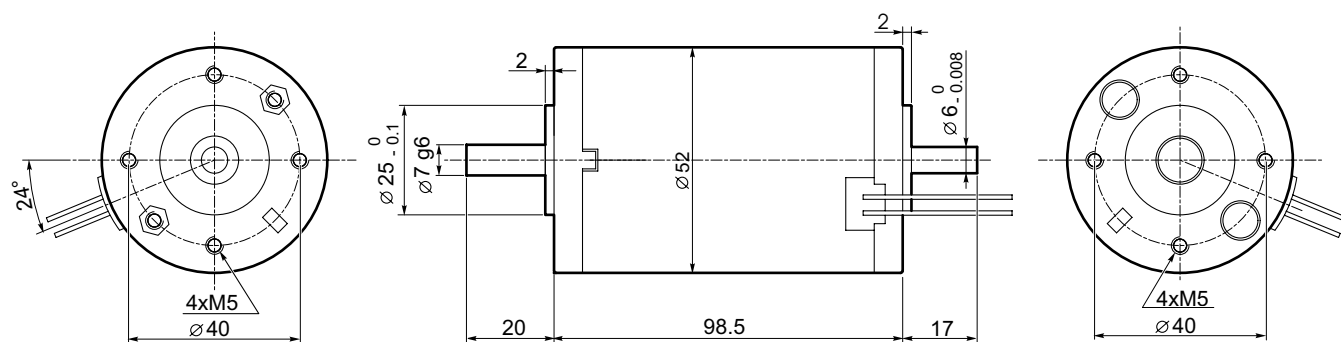

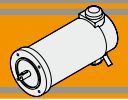

EC035.120 - EC035.240

Prestazioni

Performances

EC035.120

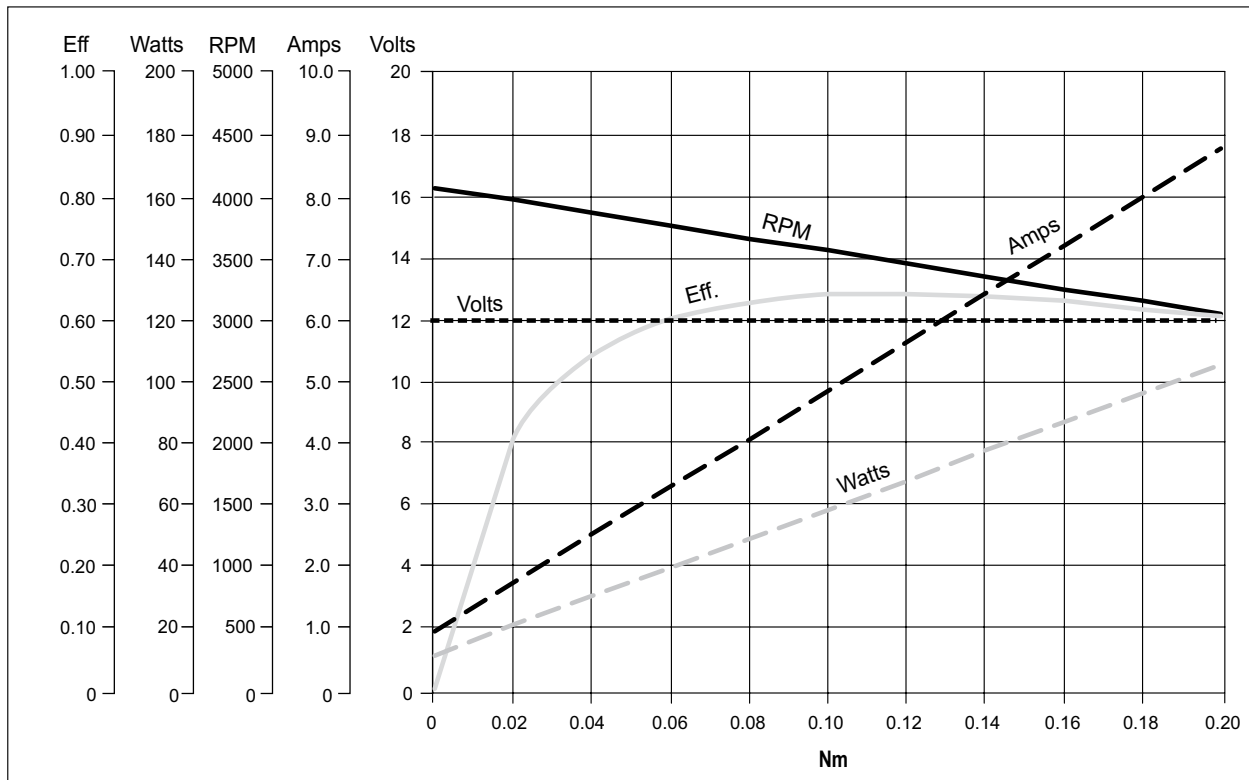

EC035.240

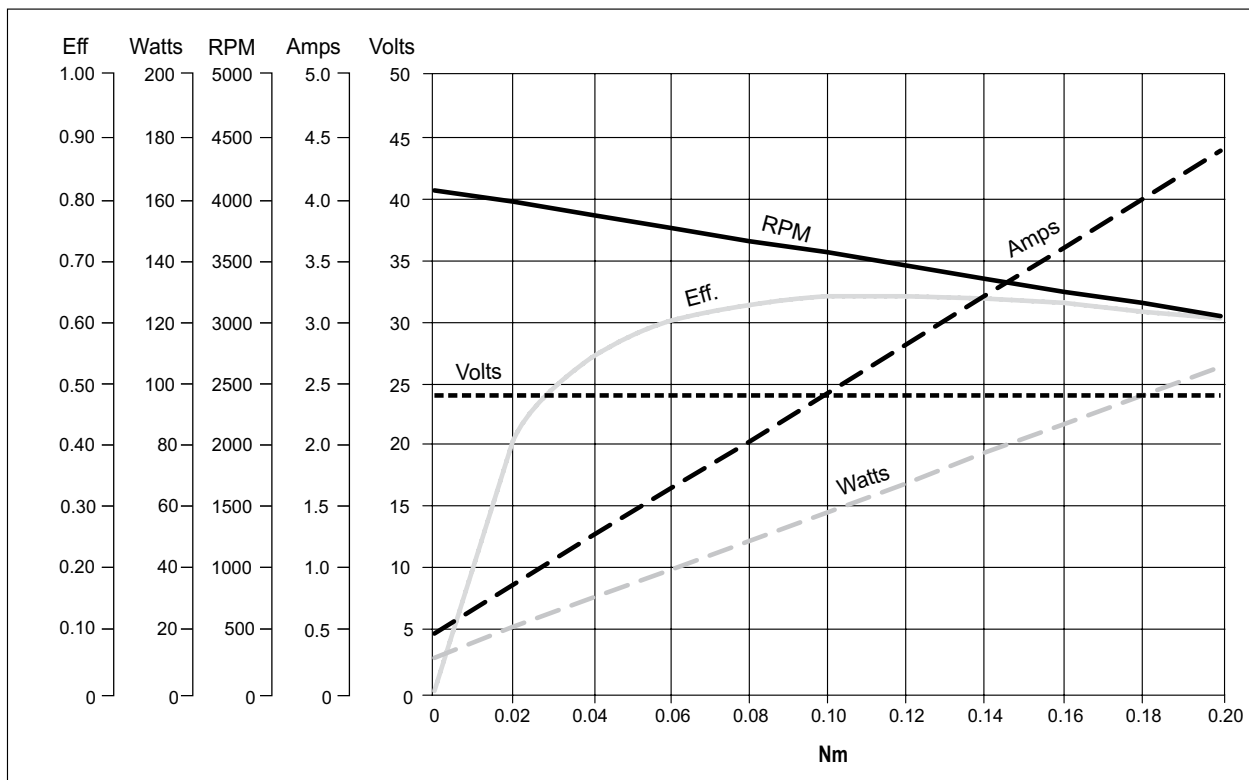

EC

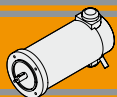

EC050.120 - EC050.240

Caratteristiche

Features

Costruzione	Tubolare, senza ventilazione
Grandezza	Ø 65 mm
Potenza	70 W S2 (50 W S1)
Magneti	2
Supporti	Cuscinetti a sfera
Fori di montaggio	4
Alimentazione	Bassa tensione, 12 o 24 Vcc
Spazzole	N° 2 interne di composto grafite-rame
Cavo di alimentazione	Lunghezza: 200 mm
Bisporgenza	Standard

Construction	Tubular, without fan
Size	Ø 65 mm
Power	70 W S2 (50 W S1)
Magnets	2
Bearings	Ball bearings
Mounting holes	4
Power supply	Low voltage, 12 or 24 Vdc
Brushes	2 inside brushes made of graphite/copper composite
Electric cable	Length: 200 mm
Rear Shaft	Standard

Tipo Type	S	Pn [W]	V [V]	I [A]	IC	FF	Mn [Nm]	n ₁ [min ⁻¹]	IP	Kg
EC050.120	S1	50	12	6.5	F	1	0.16	3000	44	1.2
	S2 15'	70		9.0			0.22			
EC050.240	S1	50	24	3.2			0.16			
	S2 15'	70		4.5			0.22			

Dimensioni

Dimensions

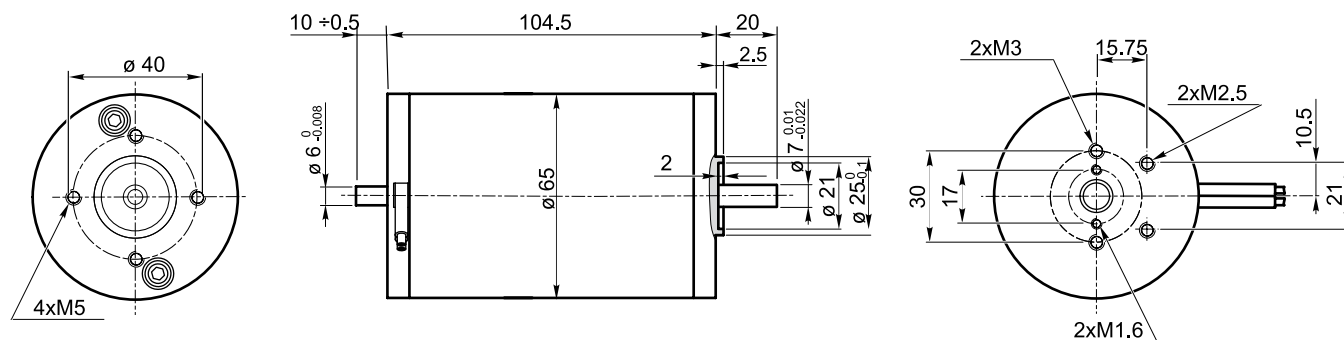

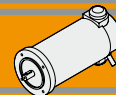

EC050.120 - EC050.240

Prestazioni

Performances

EC050.120

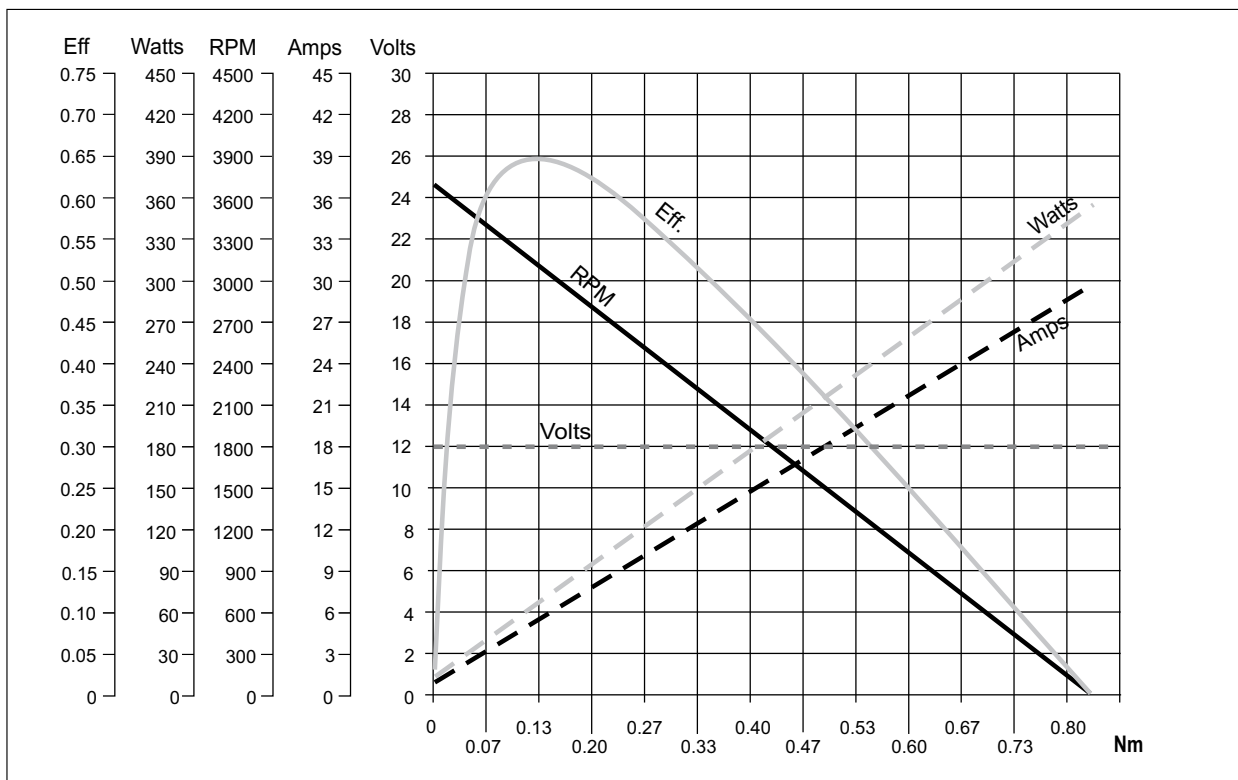

EC050.240

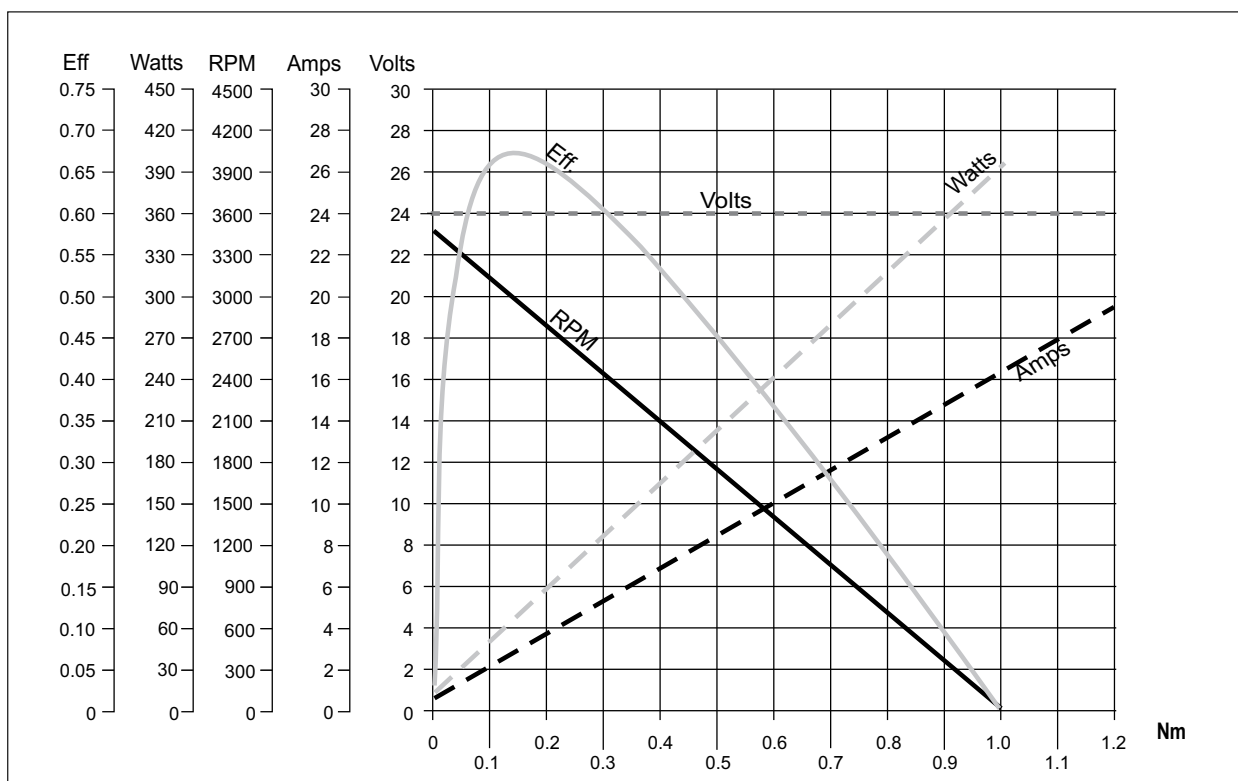

EC

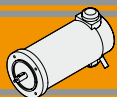

EC070.120 - EC070.240

Caratteristiche

Features

Costruzione	Tubolare, senza ventilazione
Grandezza	Ø 65 mm
Potenza	100 W S2
Magneti	2
Supporti	Cuscinetti a sfera
Fori di montaggio	4
Alimentazione	Bassa tensione, 12 o 24 Vcc
Spazzole	N° 2 interne di composto grafite-rame
Cavo di alimentazione	Lunghezza: 1000 mm

Construction	Tubular, without fan
Size	Ø 65 mm
Power	100 W S2
Magnets	2
Bearings	Ball bearings
Mounting holes	4
Power supply	Low voltage, 12 or 24 Vdc
Brushes	2 inside brushes made of graphite/copper composite
Electric cable	Length: 1000 mm

Tipo Type	S	Pn [W]	V [V]	I [A]	IC	FF	Mn [Nm]	n ₁ [min ⁻¹]	IP	Kg
EC070.120	S2 20'	100	12	11.8	F	1	0.31	3000	44	1.7
EC070.240	S2 20'	100	24	5.9			0.31			

Nota: Per servizio continuativo contattare il Servizio Tecnico.
 Note: For continuous duty please contact our Technical Service.

Dimensioni

Dimensions

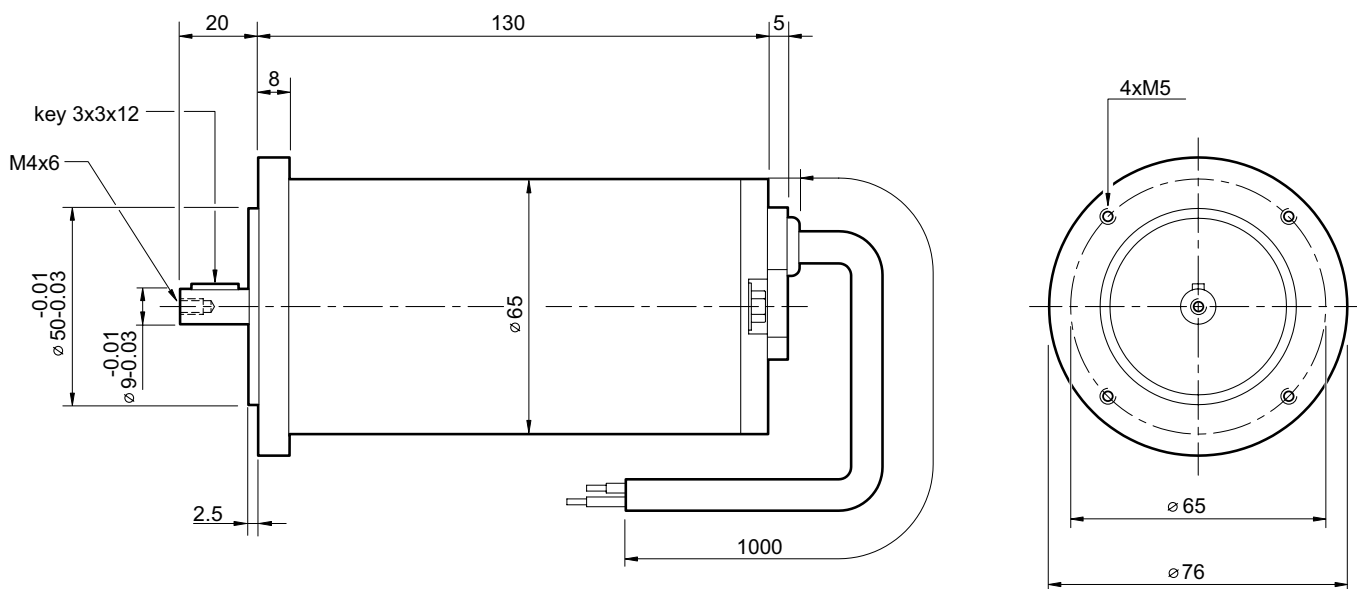

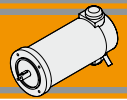

EC070.120 - EC070.240

Prestazioni

Performances

EC070.120

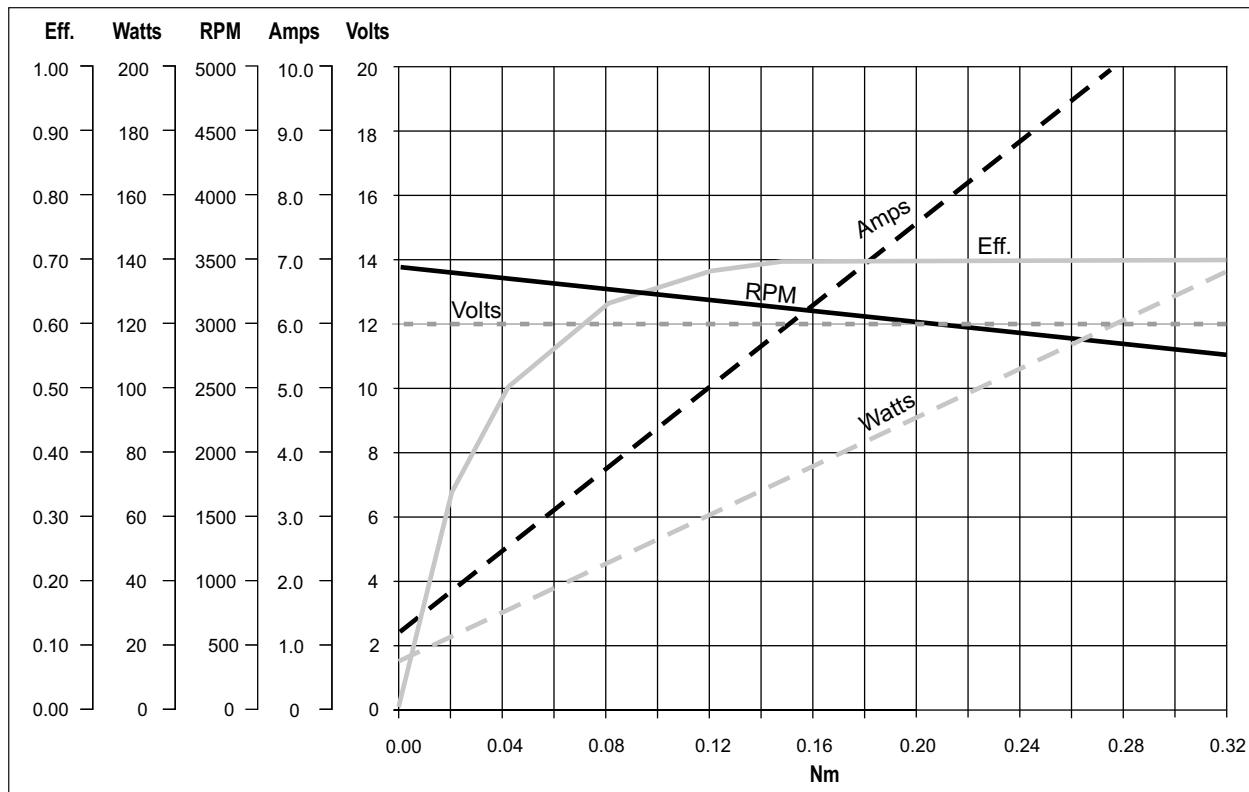

EC070.240

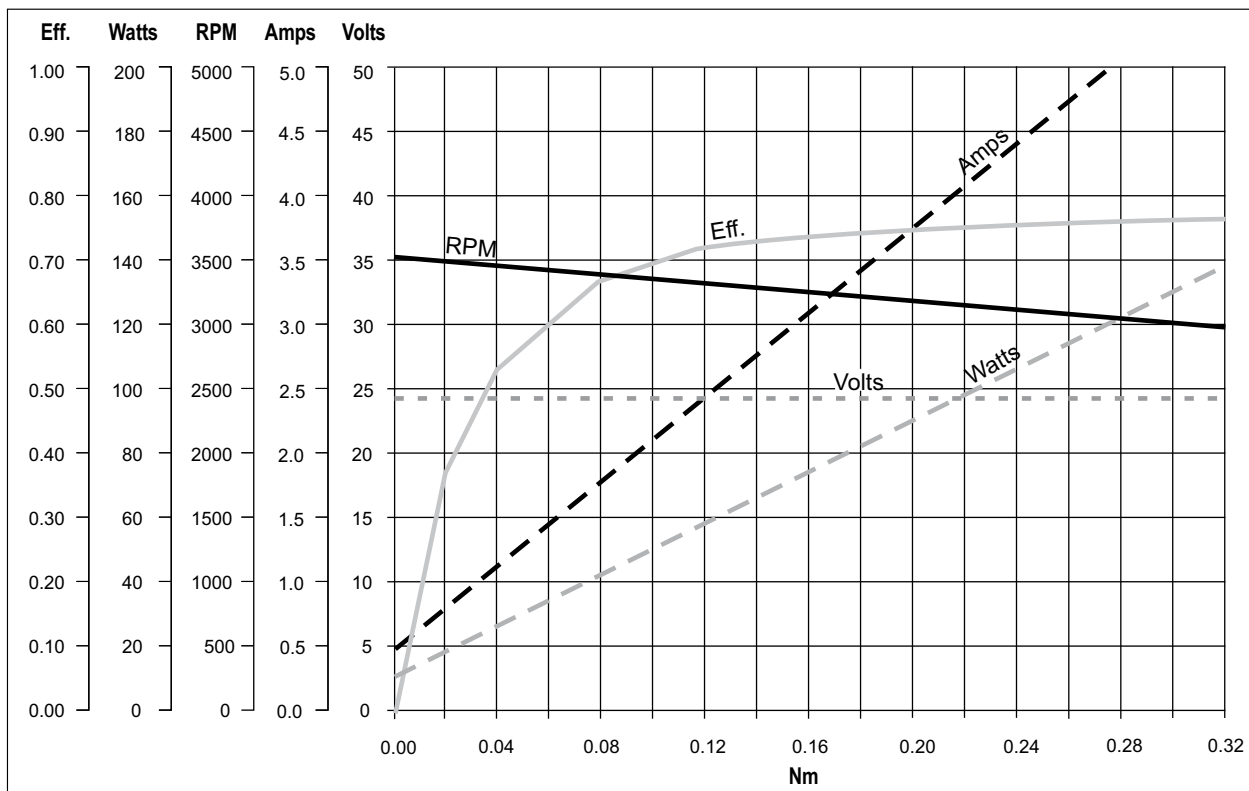

EC

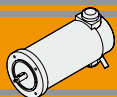

EC100.120 - EC100.240 - EC100.24E

Caratteristiche

Features

Costruzione	Tubolare, senza ventilazione
Grandezza	Ø 80 mm
Potenza	140 W S2 (100 W S1)
Magneti	2
Supporti	Cuscinetti a sfera
Fori di montaggio	4
Alimentazione	Bassa tensione, 12 o 24 Vcc
Spazzole	N° 2 di composto grafite-rame
Dimensione spazzole	LxPxH = 17.1 x 6.5 x 16.7 mm
Cavo di alimentazione	Lunghezza: 1000 mm
Bisporgenza	Standard solo EC100.24E

Construction	Tubular, without fan
Size	Ø 80 mm
Power	140 W S2 (100 W S1)
Magnets	2
Bearings	Ball bearings
Mounting holes	4
Power supply	Low voltage, 12 or 24 Vdc
Brushes	2 inside brushes made of graphite/copper composite
Brushes size	LxWxH = 17.1 x 6.5 x 16.7 mm
Electric cable	Length: 1000 mm
Rear shaft	Standard only EC100.24E

Tipo Type	S	Pn [W]	V [V]	I [A]	IC	FF	Mn [Nm]	n ₁ [min ⁻¹]	IP	Kg
EC100.120	S1	100	12	12	F	1	0.31	3000	44	2.7
	S2 25'	140		16.8			0.43			
EC100.240	S1	100	24	6			0.31			
	S2 25'	140		8.4			0.43			
EC100.24E	S1	100	24	6			0.31			
	S2 25'	140		8.4			0.43			

Dimensioni

Dimensions

**EC100.120
EC100.240**

56 B14	
L	153
D	80
S	65
C (-0.03 / -0.01)	50
63B14*	
L	155
D	90
S	75
C (-0.03 / -0.01)	60

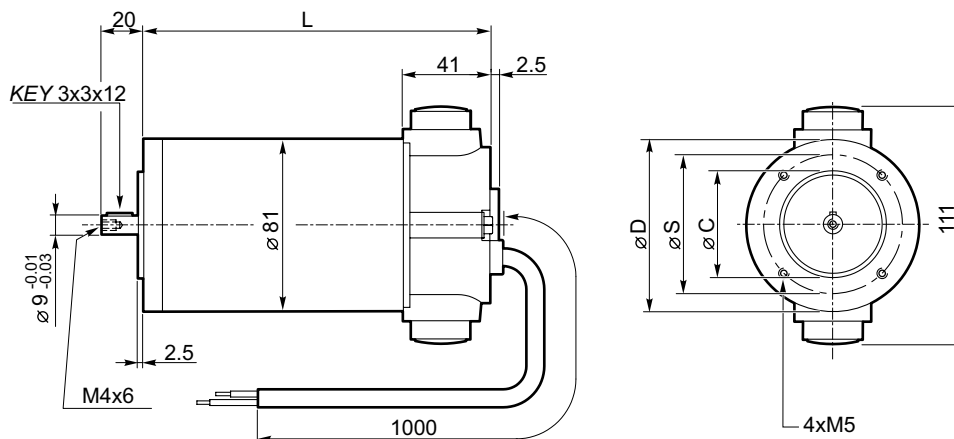

* Usare boccola 9/11
 * Use sleeve 9/11

EC100.24E

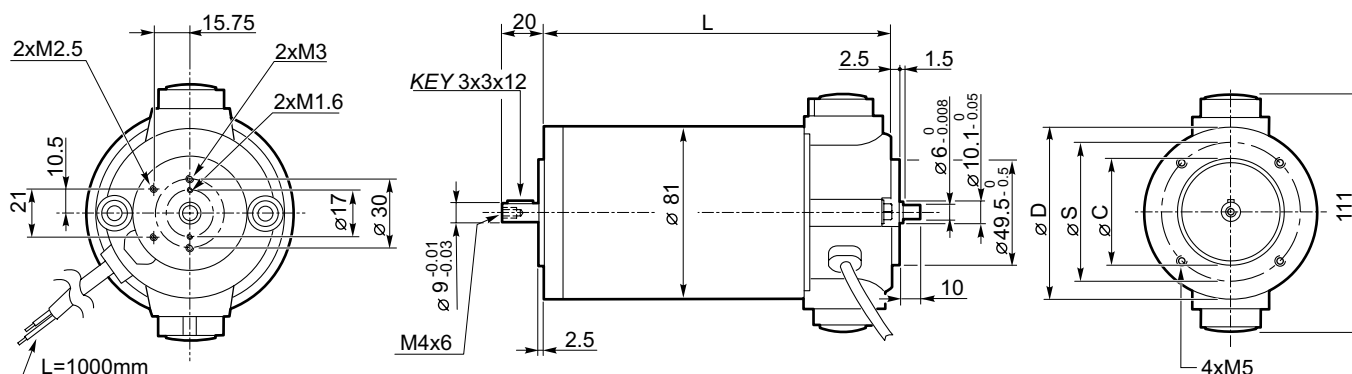

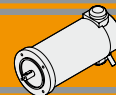

EC100.120 - EC100.240 - EC100.24E

Prestazioni

Performances

EC100.120

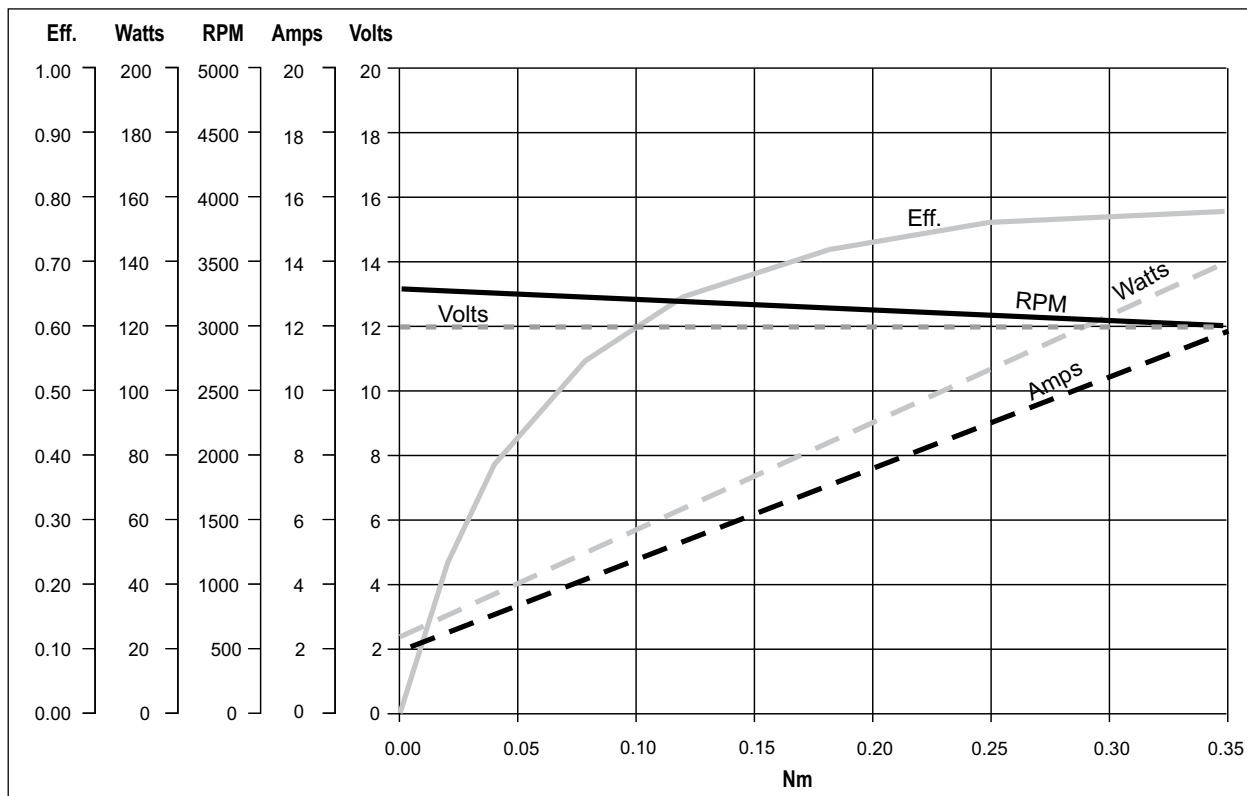

EC100.240 - EC100.24E

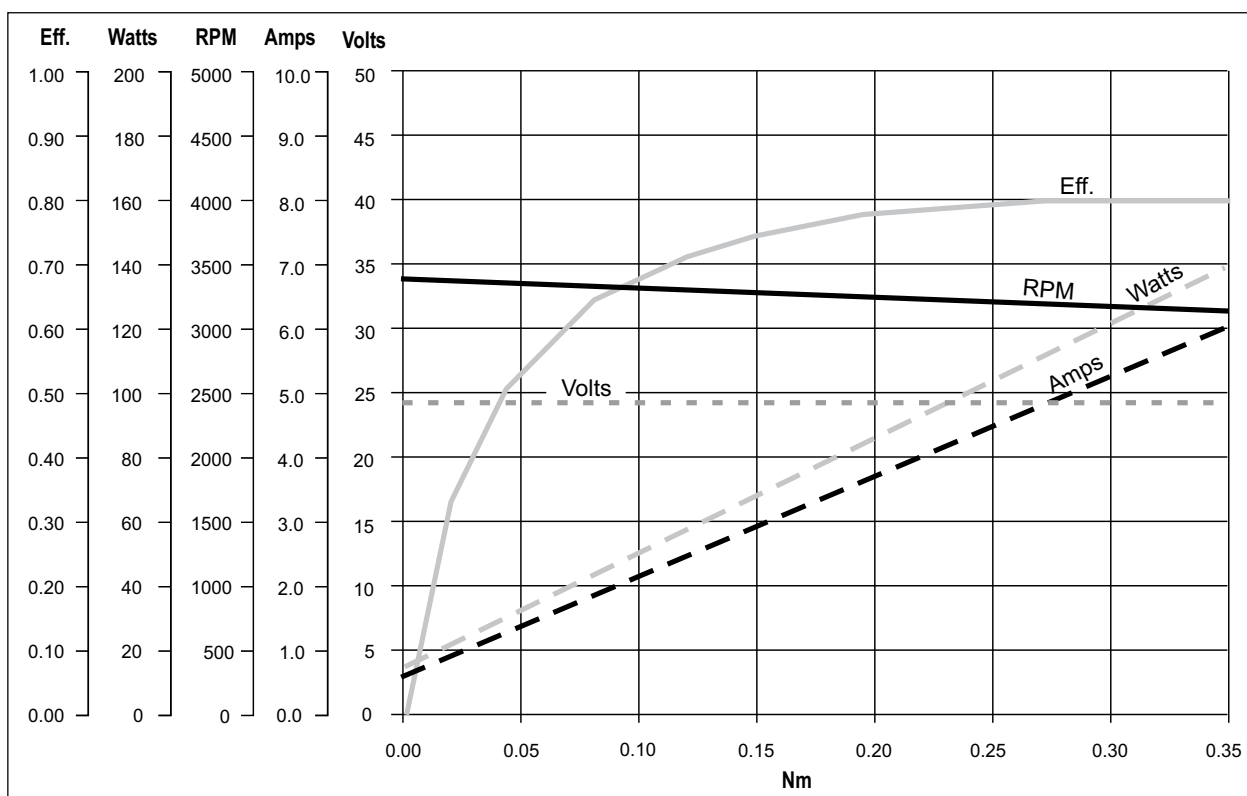

EC

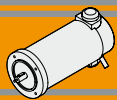

EC180.120 - EC180.240 - EC180.24E

Caratteristiche

Features

Costruzione	Tubolare, senza ventilazione
Grandezza	Ø 80 mm
Potenza	250 W S2 (180 W S1)
Magneti	2
Supporti	Cuscinetti a sfera
Fori di montaggio	4
Alimentazione	Bassa tensione, 12 o 24 Vcc
Spazzole	N° 2 di composto grafite-rame
Dimensione spazzole	LxPxH = 17.1 x 6.5 x 16.7 mm
Cavo di alimentazione	Lunghezza: 1000 mm
Bisporgenza	Standard solo EC180.24E

Construction	Tubular, without fan
Size	Ø 80 mm
Power	250 W S2 (180 W S1)
Magnets	2
Bearings	Ball bearings
Mounting holes	4
Power supply	Low voltage, 12 or 24 Vdc
Brushes	2 inside brushes made of graphite/copper composite
Brushes size	LxPxH = 17.1 x 6.5 x 16.7 mm
Electric cable	Length: 1000 mm
Rear shaft	Standard only EC180.24E

Tipo Type	S	Pn [W]	V [V]	I [A]	IC	FF	Mn [Nm]	n ₁ [min ⁻¹]	IP	Kg	
EC180.120	S1	180	12	21.5	F	1	0.57	3000	IP44	3.4	
	S2 25'	250		30			0.8				
EC180.240	S1	180	24	10.8			0.57				0.8
	S2 25'	250		15							
EC180.24E	S1	180		10.8			0.57				0.8
	S2 25'	250		15							

Dimensioni

Dimensions

**EC180.120
EC180.240**

56 B14	
L	185
D	80
S	65
C (-0.03 / -0.01)	50
63B14*	
L	187
D	90
S	75
C (-0.03 / -0.01)	60

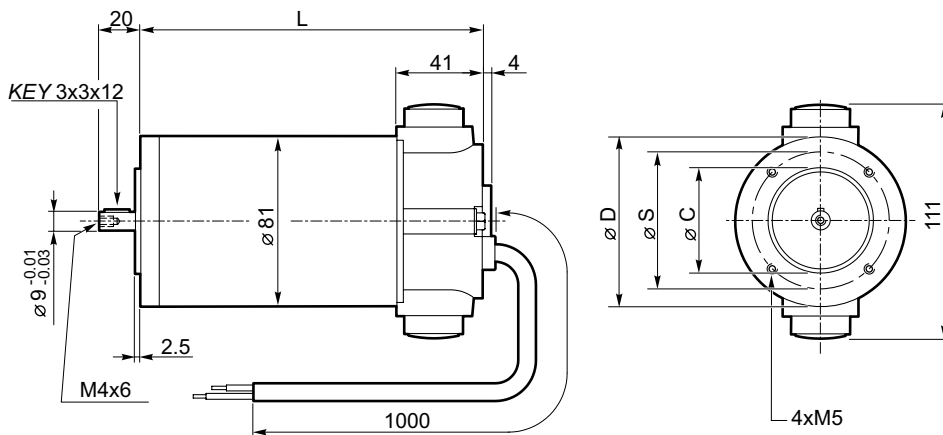

* Usare boccola 9/11
 * Use sleeve 9/11

EC180.24E

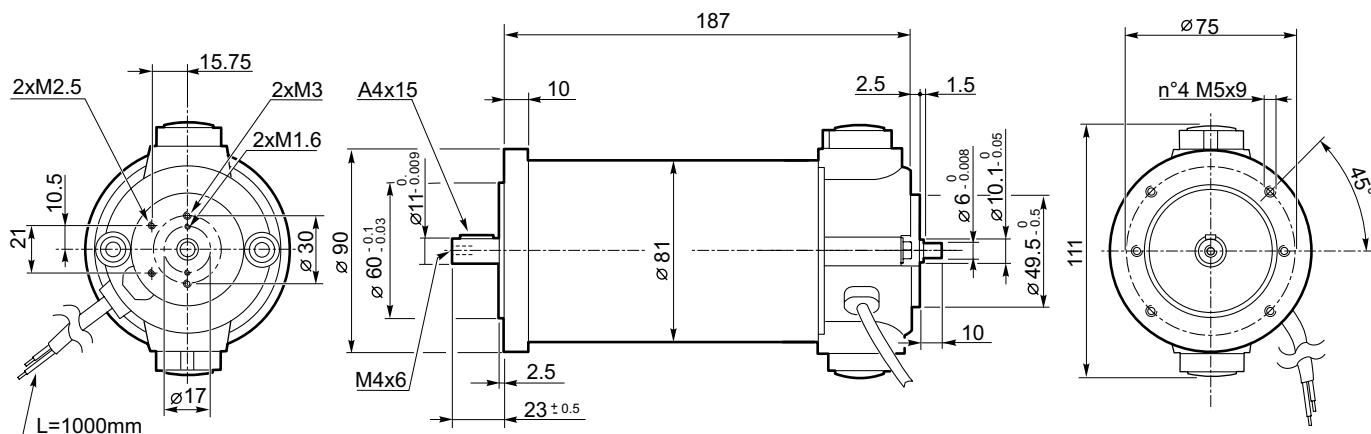

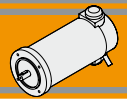

EC180.120 - EC180.240 - EC180.24E

Prestazioni

Performances

EC180.120

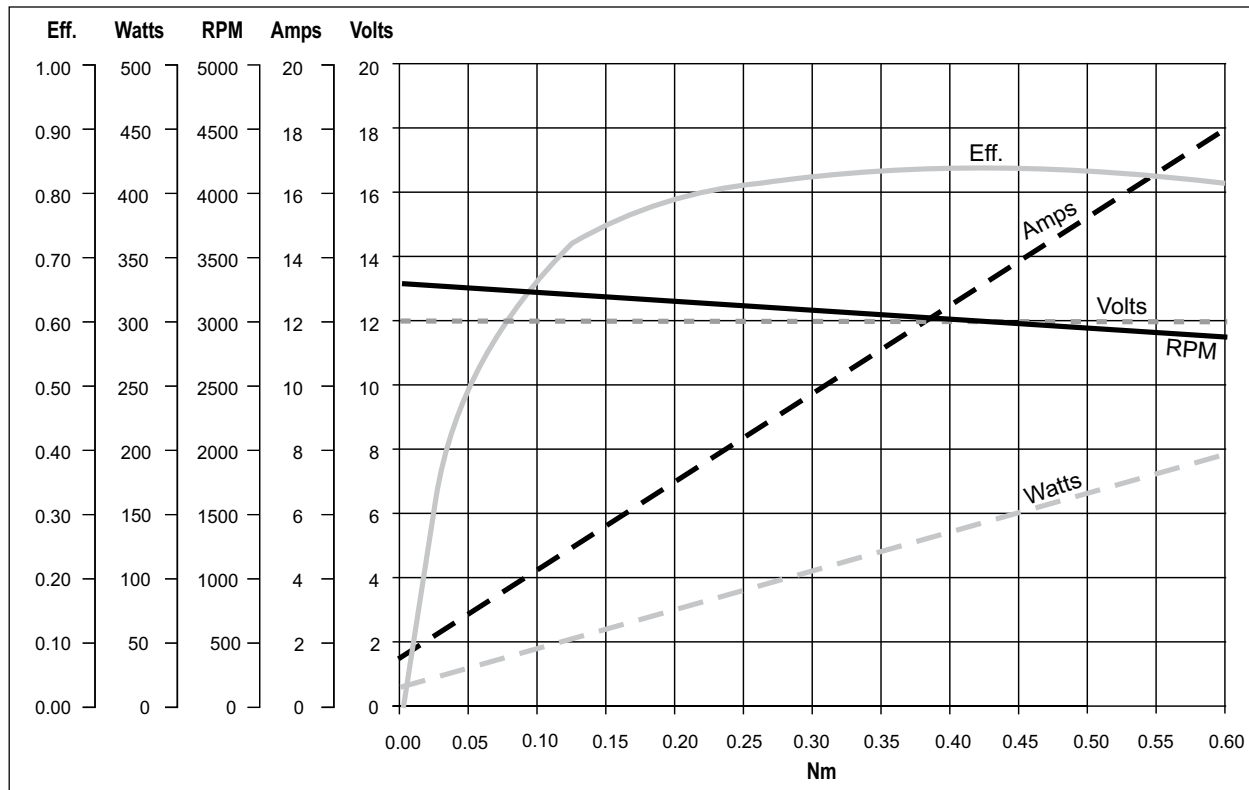

EC180.240 - EC180.24E

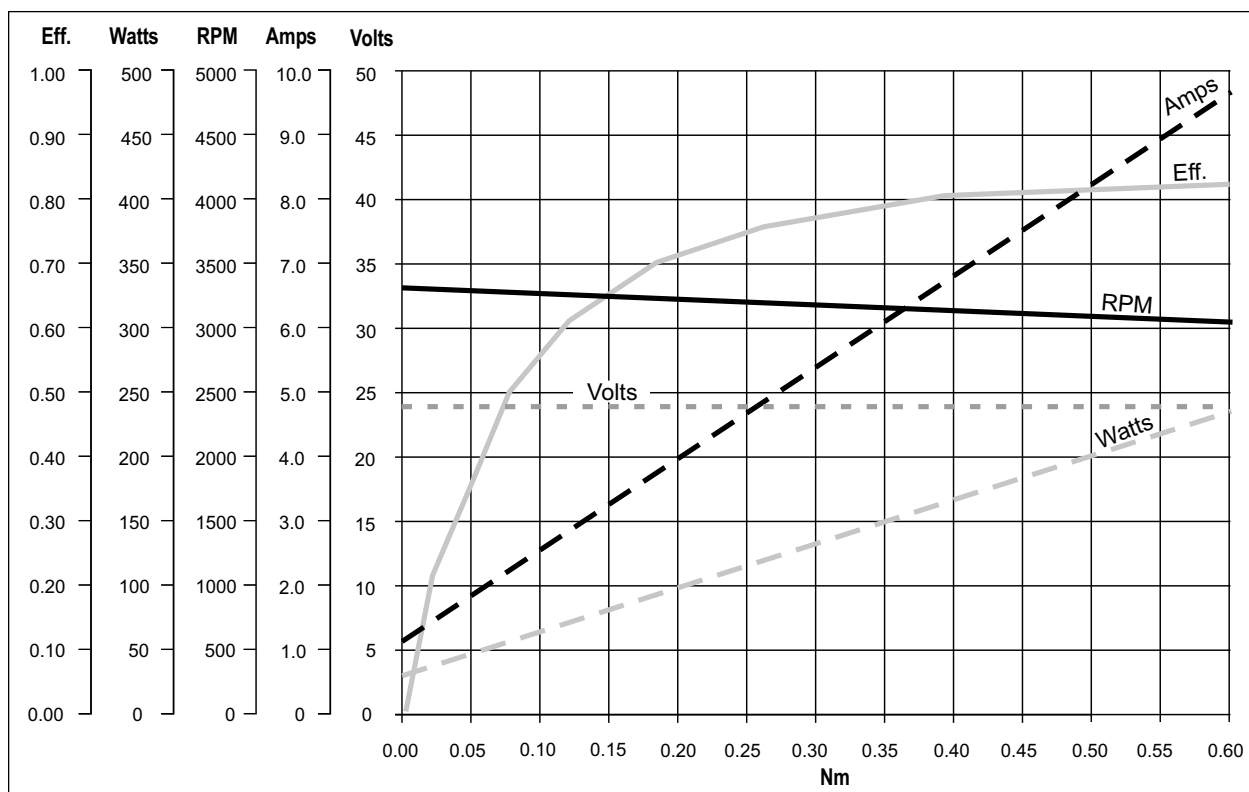

EC

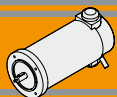

EC350.120 - EC350.240

Caratteristiche

Features

Costruzione	Tubolare, senza ventilazione
Grandezza	Ø 110 mm
Potenza	500 W S2 (350 W S1)
Magneti	4
Supporti	Cuscinetti a sfera
Fori di montaggio	8
Alimentazione	Bassa tensione, 12 o 24 Vcc
Spazzole	N° 4 di composto grafite-rame
Dimensione spazzole	LxPxH = 18.9 x 9.5 x 16.7 mm
Terminali	2 con dadi di fissaggio

Construction	Tubular, without fan
Size	Ø 110 mm
Power	500 W S2 (350 W S1)
Magnets	4
Bearings	Ball bearings
Mounting holes	8
Power supply	Low voltage, 12 or 24 Vdc
Brushes	4 brushes made of graphite/copper composite
Brushes size	LxPxH = 18.9 x 9.5 x 16.7 mm
Leads terminals	2, with double nut

Tipo Type	S	Pn [W]	V [V]	I [A]	IC	FF	Mn [Nm]	n ₁ [min ⁻¹]	IP	Kg
EC350.120	S1	350	12	42	F	1	1.12	3000	44	5.1
	S2 30'	500		58.8			1.57			
EC350.240	S1	350	24	21			1.12			5.3
	S2 30'	500		29.4			1.57			

Dimensioni

Dimensions

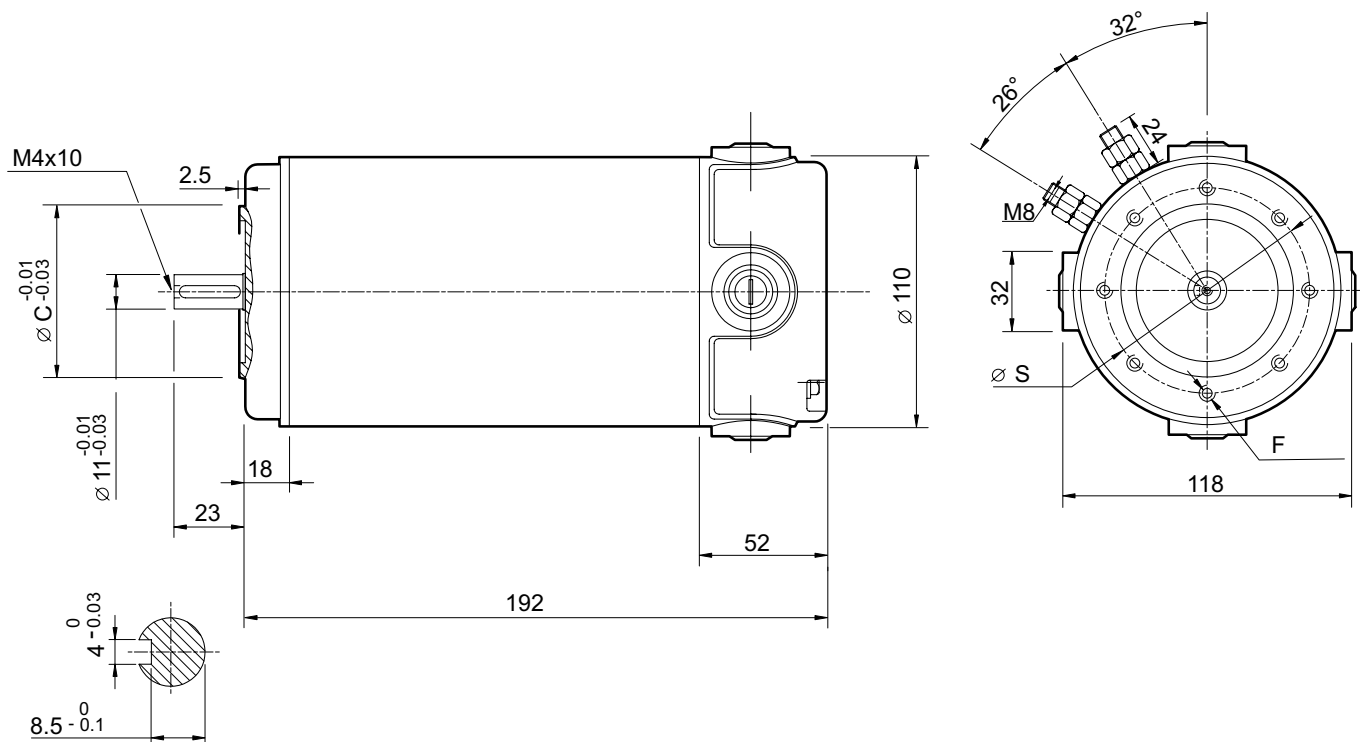

63 B14		71 B14*	
S	75	S	85
C (-0.03 / -0.01)	60	C (-0.03 / -0.01)	70
F	8 - M5	F	8 - M6

* Usare boccia 11/14
 * Use sleeve 11/14

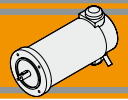

EC350.120 - EC350.240

Prestazioni

Performances

EC350.120

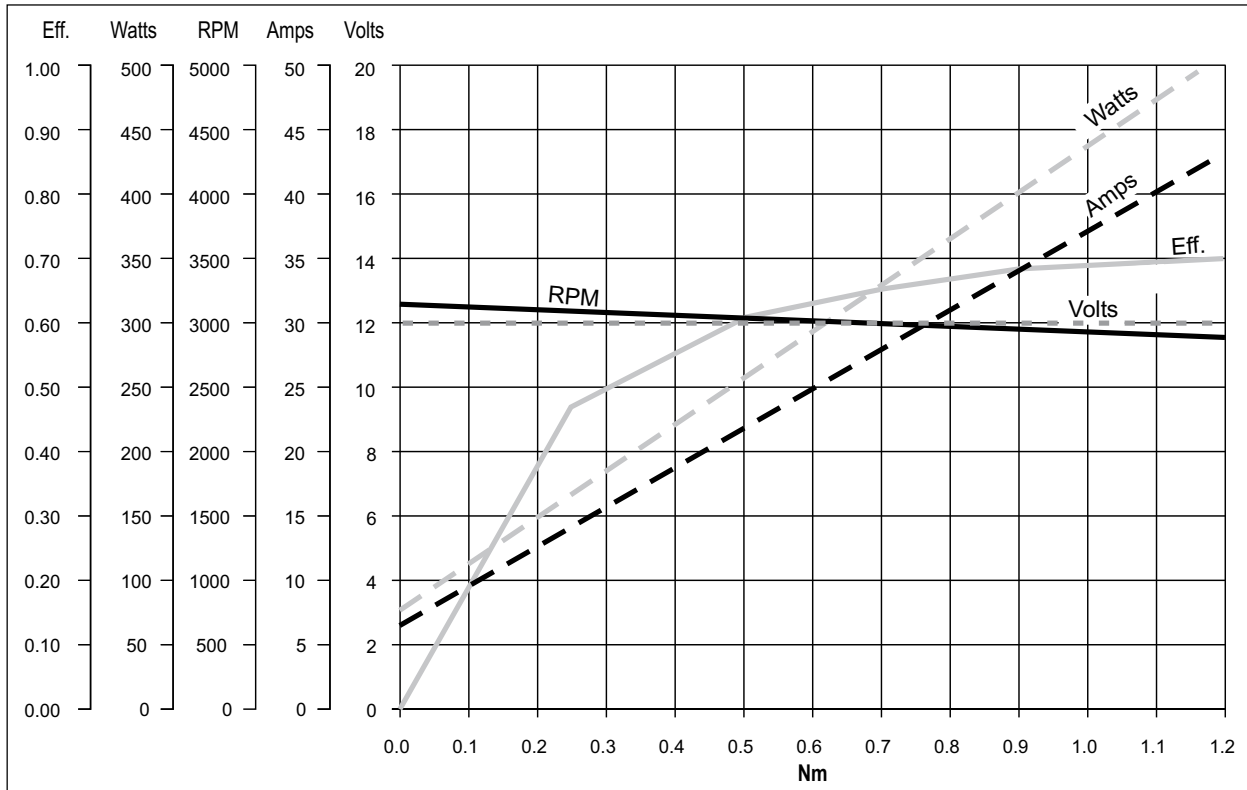

EC350.240

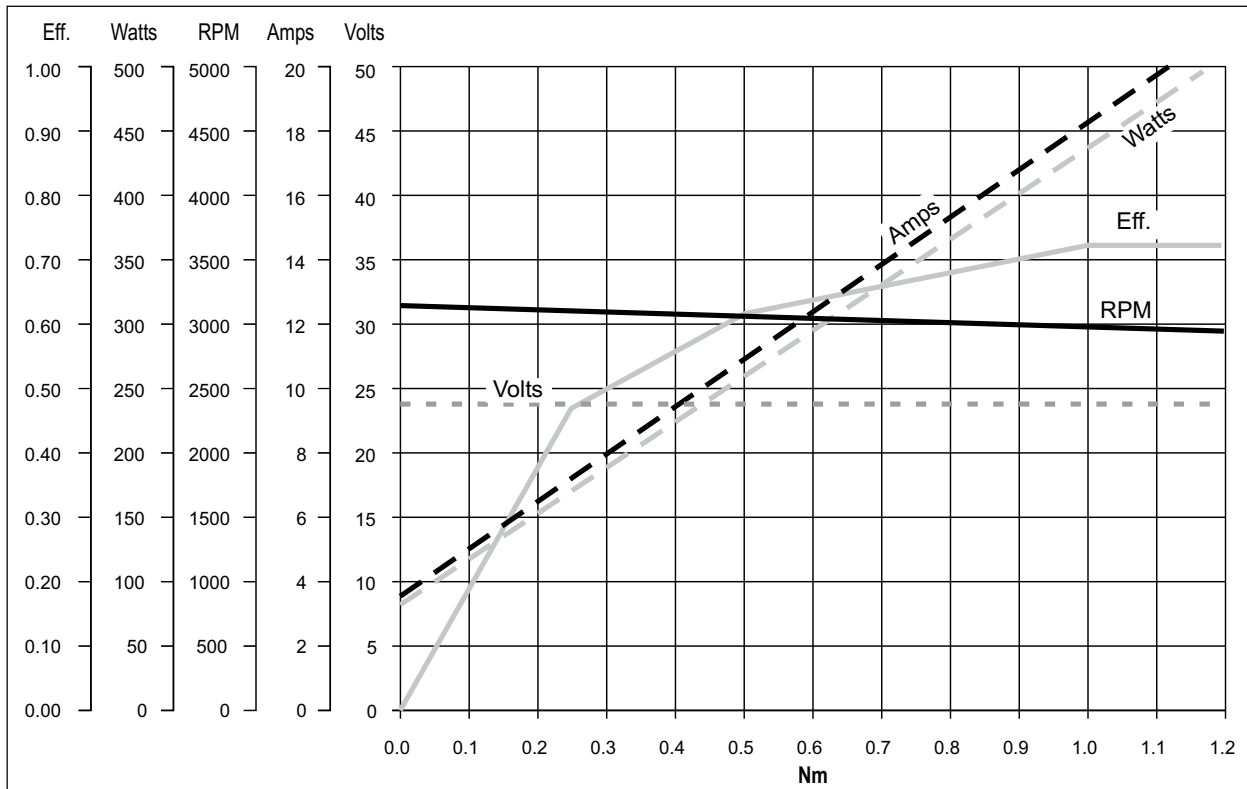

EC

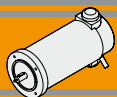

EC600.120 - EC600.240

Caratteristiche

Features

Costruzione	Tubolare, senza ventilazione
Grandezza	Ø 110 mm
Potenza	800 W S2 (600 W S1)
Magneti	4
Supporti	Cuscinetti a sfera
Fori di montaggio	8
Alimentazione	Bassa tensione, 12 o 24 Vcc
Spazzole	N° 4 di composto grafite-rame
Dimensione spazzole	LxPxH = 18.9 x 9.5 x 16.7 mm
Terminali	2 con doppio dado di fissaggio

Construction	Tubular, without fan
Size	Ø 110 mm
Power	800 W S2 (600 W S1)
Magnets	4
Bearings	Ball bearings
Mounting holes	8
Power supply	Low voltage, 12 or 24 Vdc
Brushes	4 brushes made of graphite/copper composite
Brushes size	LxPxH = 18.9 x 9.5 x 16.7 mm
Leads terminals	2, with double nut

Tipo Type	S	Pn [W]	V [V]	I [A]	IC	FF	Mn [Nm]	n ₁ [min ⁻¹]	IP	Kg
EC600.120	S1	600	12	71	F	1	1.91	3000	44	6.6
	S2 30'	800		94.4			2.54			
EC600.240	S1	600	24	35.5			1.91			7.1
	S2 30'	800		47.2			2.54			

Dimensioni

Dimensions

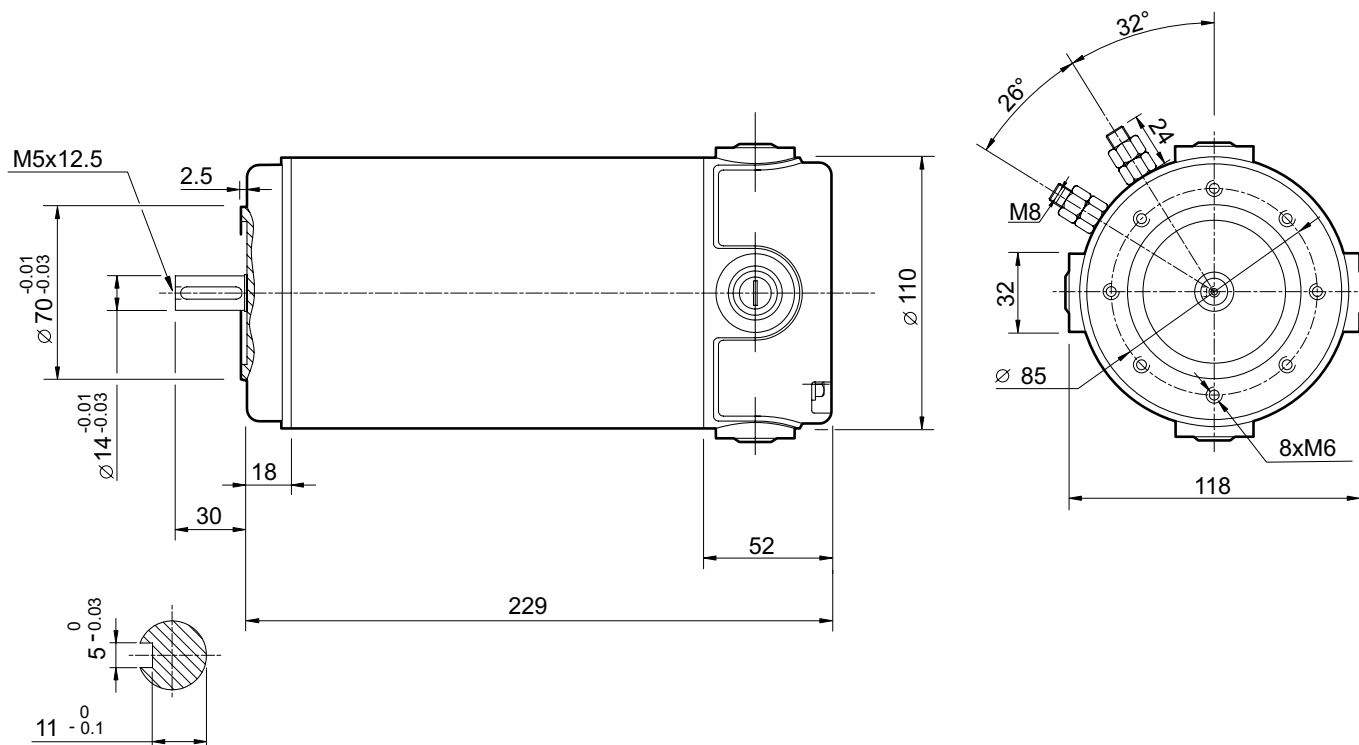

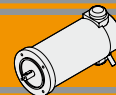

EC600.120 - EC600.240

Prestazioni

Performances

EC600.120

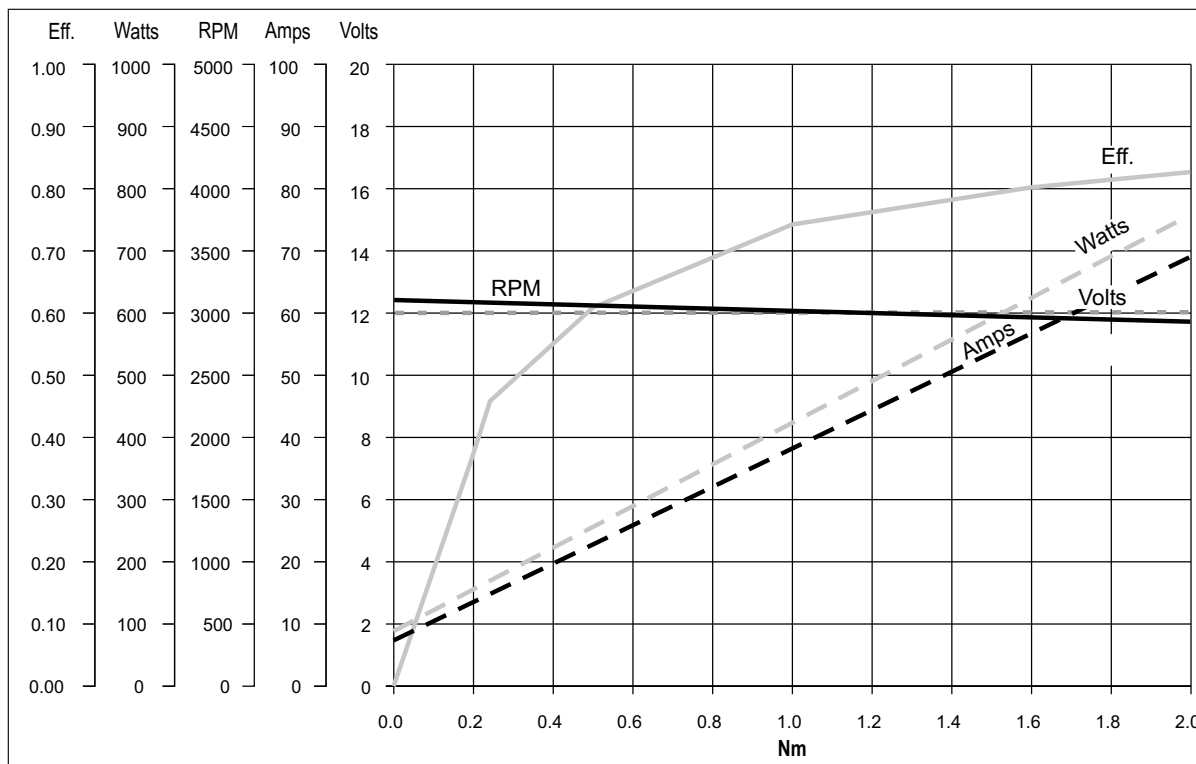

EC600.240

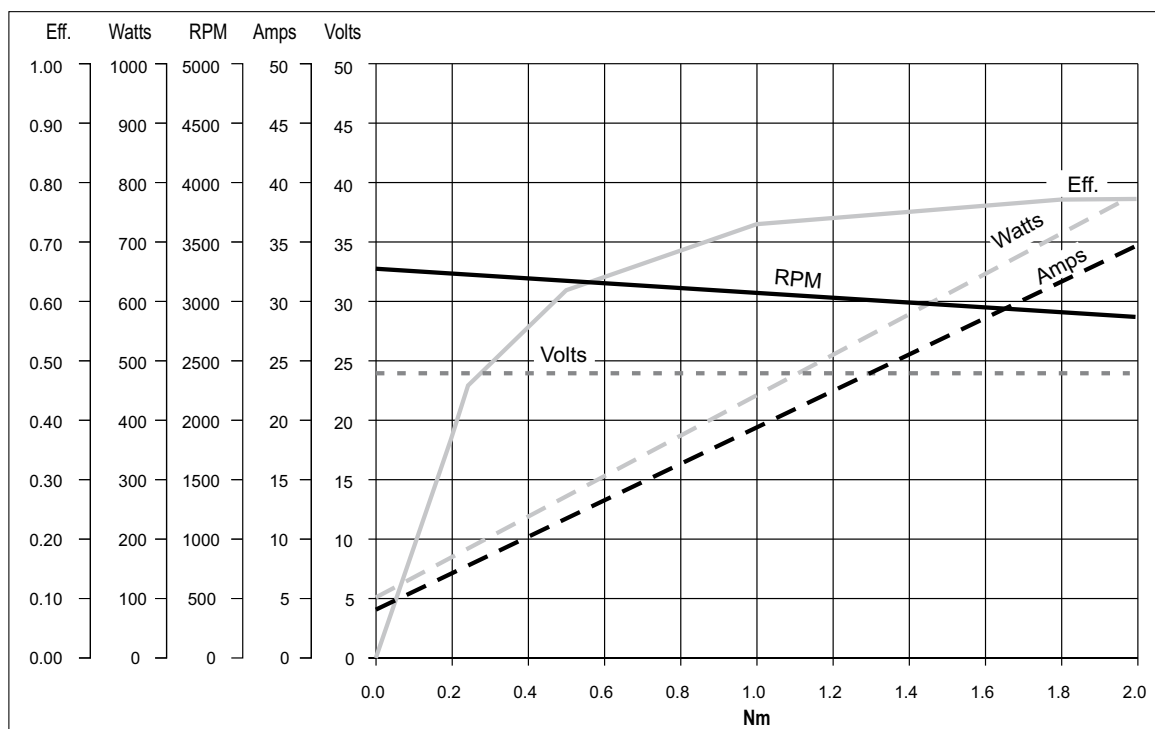

EC

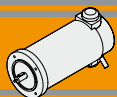

Legenda / Glossario dei grafici

Key / Diagram Glossary

Dato un motore in C.C., la velocità di rotazione è funzione lineare della coppia; così pure la corrente assorbita è una funzione lineare della coppia. Velocità e corrente variano in maniera sensibile al variare del carico.

With a D.C. motor, the rotational speed is a linear function of the torque. In the same way, the absorbed current is also a linear function of the torque. Speed and current change a lot against applied torque.

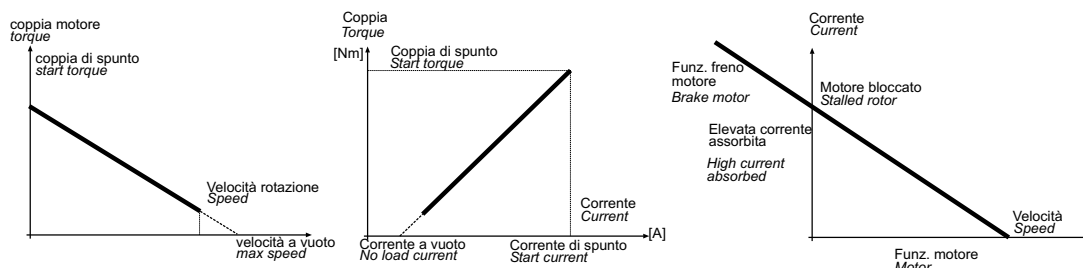

La potenza utile (potenza all' albero) si ricava dalla formula:

$$P_n [W] = M_n \cdot S = \frac{2\pi}{60} \cdot n_1 \cdot M_n$$

The output power is calculated using the formula:

$$P_n [W] = M_n \cdot S = \frac{2\pi}{60} \cdot n_1 \cdot M_n$$

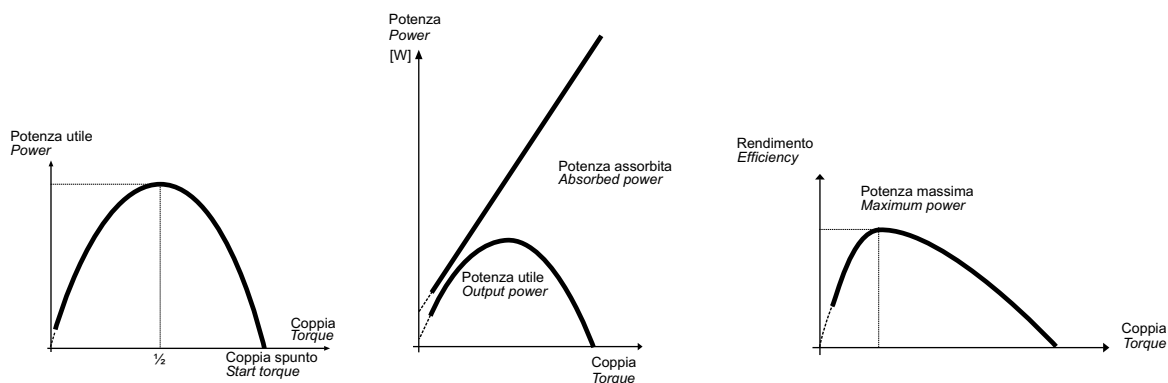

Poiché la tensione di alimentazione è costante mentre la corrente è linearmente crescente al crescere della coppia, l'andamento della potenza assorbita è un retta crescente. Dal rapporto tra la potenza meccanica e la potenza assorbita si ottiene il grafico dell'efficienza.

Since the supply voltage is constant, whereas the current increases in a linear manner as the torque increases, the absorbed power trend is a straight line going up. Efficiency is shown from the ratio between the output power and the absorbed power.

Formule utili

Useful formulas

$$\eta = \frac{P_n}{P_a}$$

$$P_a = V \cdot I$$

$$P_n = V \cdot I \cdot \eta$$

$$P_n = M_n \cdot S_v$$

$$S_v = \frac{n_1}{9.55}$$

$$\eta = \frac{P_n}{P_a}$$

$$P_a = V \cdot I$$

$$P_n = V \cdot I \cdot \eta$$

$$P_n = M_n \cdot S_v$$

$$S_v = \frac{n_1}{9.55}$$

[HP] · 746 = [W].
 Esempio 2 HP = circa 1500 W.

[HP] · 746 = [W].
 Example 2 HP = approx. 1500 W.

S	—	Servizio	<i>Duty</i>
P_n	[W]	Potenza in uscita	<i>Rated power</i>
P_a	[W]	Potenza assorbita	<i>Absorbed power</i>
M_n	[Nm]	Coppia nominale	<i>Rated torque</i>
V	[V]	Tensione	<i>Voltage</i>
I	[A]	Corrente assorbita	<i>Absorbed current</i>
n₁	[min ⁻¹]	Numero giri motore	<i>Motor speed</i>
S_v	[rad/s]	Velocità angolare	<i>Angular speed</i>
IC	—	Classe d'isolamento termico	<i>Thermal insulation class</i>
FF	—	Fattore di forma	<i>Form factor</i>
IP	—	Classe di protezione	<i>protection class</i>
η	—	Rendimento	<i>Efficiency</i>
Kg	—	Peso	<i>Weight</i>

HEADQUARTERS



TRANSTECNO SRL
Via Caduti di Sabbiuno, 11 D/E
40011 Anzola Emilia (BO) - ITALY
Tel. +39.051.6425811
Fax +39.051.734943
info@transtecno.com
www.transtecno.com

MANUFACTURING PLANT



HANGZHOU TRANSTECNO
POWER TRANSMISSIONS CO; LTD
26, No.1 Street
Hangzhou Economic
& Technological
Development Area
Hangzhou - CHINA
Tel. +86.571.86921603
Fax +86.571.86921810
info-china@transtecno.com
www.transtecno.cn

SALES OFFICES & WAREHOUSES



GEARTECNO ITALIA SRL
Via Ferrari, 27/11
41043 Fraz. Corlo,
Formigine (MO) - ITALY
Tel. +39.059.557522
Fax +39.059.557439
info@geartecno.com
www.geartecno.com



GEARTECNO HOLLAND B.V.
De Stuwdam 43
ind. terrein Wieken/Vinkenhof
3815 KM Amersfoort
THE NETHERLANDS
Tel. +31.(0)33.4519505
Fax +31.(0)33.4519506
info@geartecno.nl
www.geartecno.nl

TRANSTECNOTM
THE MODULAR GEARMOTOR

www.transtecno.com

SALES OFFICES



SALES OFFICE BRAZIL
Rua Dr. Freire Alemão 155 / 402
CEP. 90450-060
Auxiliadora Porto Alegre-RS-BRAZIL
Tel. +55.51.3251.5447
Fax +55.51.3251.5447
Mobile +55 51 811 45 962
braziloffice@transtecno.com
www.transtecno.com.br



SALES OFFICE OCEANIA
Unit 7, 387-393 Old Geelong
Road, Hoppers Crossing,
Victoria 3029 - AUSTRALIA
Tel. +61.03.9369.9774
Fax +61.03.9369.9775
Mobile +61.0438.060.997
oceaniaoffice@transtecno.com



SALES OFFICE SPAIN
C/Major, Nr.1
17256 Fontclara - SPAIN
Tel. +34.626141978
spainoffice@transtecno.com
www.transtecno.es



SALES OFFICE EASTERN
EUROPE & MIDDLE EAST
St. Magnolienweg 4
D-31860 Emmertal - GERMANY
Tel. +49.5151.963076
Fax +49.5151.963076
Mobile +49.172.4044907
emeoffice@transtecno.com



SALES OFFICE USA
509 10th St Alton, Iowa,
51003 - USA
Tel: +1 712-540-9080
usaoffice@transtecno.com



SALES OFFICE SOUTH KOREA
D-248, Namdong Industrial
Complex 631,
Gojan-dong Namdong-gu Incheon,
KOREA
Tel. +82 70 8288 2107
Fax. +82 32 815 2107
Mobile: +82 10 5094 2107
koreaoffice@transtecno.com



SALES OFFICE GUANGZHOU
Room 832, Wanny International
No.167,
Linhe west road, Guangzhou City,
CHINA
Tel: + 86 20 38776057
Fax: + 86 20 38776127
Mobile: + 86.139.25169633
guangzhouoffice@transtecno.com