

**TOPBALL®**

TOPBALL

# TOPBALL®

The NB TOPBALL is a linear motion mechanism utilizing the rotational motion of ball elements. NB's self-aligning TOPBALL can be designed into many different applications such as factory automated equipment, machine tools, industrial machines, electrical equipment, optical and measuring instruments.

## STRUCTURE AND ADVANTAGES

### Higher Load Capacity and Longer Travel life

NB's uniquely designed load plate provides circular arch contact to the ball element resulting in a greater dispersion of the load, enabling TOPBALL to provide up to three times the load capacity therefore 27 times the travel life of conventional slide bushings.

### Self Aligning Capability

Load plates are thinner at the ends to provide a pivot point at the center of the plate. The center acts as a fulcrum to compensate for any slight misalignment between the shaft and the housing bore that might be caused by inaccurate machining, mounting errors or shaft deflection.

### Floating Seal

NB's unique floating seal design allows for self-alignment while maintaining equal and constant contact to the shaft. Seals do not add to the overall length of the bushing allowing for more compact designs.

### High Speed

TOPBALL meets high speed requirements. The maximum speed is 180m/min.

### Clearance Adjustable

TOPBALL load plates are designed to "float" in the outer sleeve which allows for clearance between the ball elements and shaft to best suit application requirements.

### TOPBALL Unit

This is a TOPBALL with a housing. The housing has the most appropriate bore tolerance that optimizes TOPBALL's performance.

Figure D-1 Circular Arch Design and Ground Surface Raceway

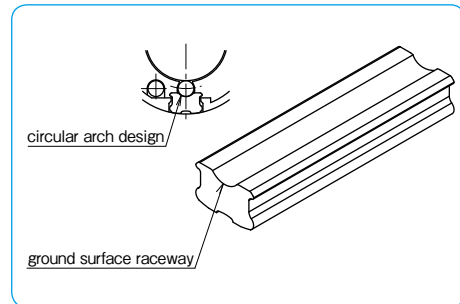
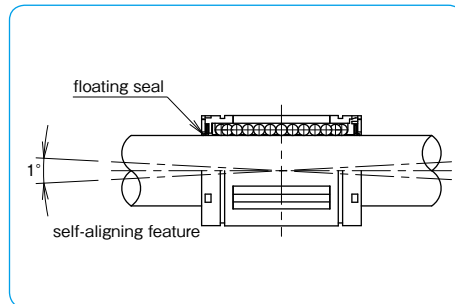

















Figure D-2 Floating Seal and Self-aligning Feature



## TYPES

Table D-1 Types

		Metric Series		Inch Series	
TOPBALL	closed type	TK  P.D-6	TW  P.D-8		
	open type	TK-OP  P.D-6	TW-OP  P.D-8		
TOPBALL Unit	closed type	TKA  P.D-10	TKA-W  P.D-11	TWA  P.D-16	TWA-W  P.D-17
	adjustable type	/		TWJ  P.D-18	TWJ-W  P.D-19
	open type	TKE  P.D-12	TKE-W  P.D-13	/	
	adjustable-open type	TKD  P.D-14	TKD-W  P.D-15	TWD  P.D-20	TWD-W  P.D-21

## LIFE CALCULATION

Since ball elements are used as the rolling element in the NB TOPBALL, the following equation is used to calculate the rated life.

$$L = \left( \frac{f_H \cdot f_T \cdot f_C}{f_W} \cdot \frac{C}{P} \right)^3 \cdot 50$$

L: rated life (km) f<sub>H</sub>: hardness coefficient  
 f<sub>T</sub>: temperature coefficient f<sub>C</sub>: contact coefficient  
 f<sub>W</sub>: applied load coefficient (Table D-2)  
 C: basic dynamic load rating (N) P: applied load (N)  
 \*Refer to page Eng-5 for the coefficients.

### Applied Load Coefficient (f<sub>w</sub>)

When calculating the applied load, the weight of the mass, inertial force, moment resulting from the motion, and the variation with time should be accurately estimated. However, it is very difficult to accurately estimate the applied load due to the existence of numerous variables, including the start/stop conditions of the reciprocating motion and of the shock/vibration. Estimation is simplified by using the values given in Table D-2.

If the stroke and number of cycles per unit time are constant, the life time is calculated using the following equation.

$$L_h = \frac{L \cdot 10^3}{2 \cdot l_s \cdot n \cdot 60}$$

L<sub>h</sub>: life time (hr) l<sub>s</sub>: stroke length (m)  
 L: rated life (km) n: number of cycles per minute (cpm)

Table D-2 Applied Load Coefficient

operating conditions	applied load coefficient f <sub>w</sub>
no shock/vibration 15 m/min or less	1.0~1.5
low shock/vibration 60 m/min or less	1.5~2.0
high shock/vibration 90 m/min or less	2.0~3.5
high shock/vibration 180 m/min or less	3.5 or more

### Relation Between Ball Circuits and Load Rating

The load rating of a slide bush varies according to the loaded position on the circumference. The value in the dimension table indicates the lowest load rating with the load placed on top of one ball circuit.  
 If the slide bush is used with two ball circuits loaded uniformly, the value will be greater.  
 Table D-3 shows the load ratio for the number of ball circuits in each case.

Table D-3 Optional Load Positions

number of rows	4	5	6
C (load rating specified on the table)			
C <sub>max</sub> (maximum load rating)			
load ratio C <sub>max</sub> /C	1.414	1.463	1.280

## MOUNTING

### Clearance and Fit

An appropriate clearance between TOPBALL and shaft is required in TOPBALL operation. Inadequate clearance may cause early failure and/or poor, rough movement. Proper clearance is determined by shaft diameter and housing bore. Table D-4 and D-5 show recommended tolerances of the shaft and housing bore.

### Shaft and Housing

To optimize NB TOPBALL performance, high precision shafts and housings are required.

- Shaft: Dimensional tolerance, surface roughness and hardness greatly affect the traveling performance of the TOPBALL.  
 The shaft must be manufactured to the following tolerances.
  - Surface roughness of 0.4Ra or less.
  - Hardness of 60 HRC or more (refer to page Eng-5).
  - The proper tolerance of the shaft diameter is recommended on Table D-4 and D-5.

The NB Shaft is an ideal component manufactured to meet these specifications. Please see pages F-1 ~ for details.

- Housing: There are a wide range of designs and manufacturing techniques for housings. NB TOPBALL Units are available as standard products. When housings are prepared separately please refer to Table D-4 and D-5 for a proper fit.

Table D-4: Recommended Tolerance for Shaft Dia. and Housing Bore

part number	shaft dia.		housing bore	
	dr mm	tol. (h6) μm	D mm	tol. (H7) μm
TK 8	8	0	16	+18/0
TK10	10	-9	19	+21 0
TK12	12	0	22	
TK16	16	-11	26	+25 0
TK20	20	0	32	
TK25	25	-13	40	0
TK30	30		47	
TK40	40	0	62	+30
TK50	50	-16	75	0

Table D-5: Recommended Tolerance for Shaft Dia. and Housing Bore

part number	shaft dia.		housing bore	
	dr inch	tol. (g6) inch	D inch	tol. (H7) inch
TW 3	.1875	-.0002	.3750	+0.0005/0
TW 4	.2500	-.0006	.5000	+0.0007
TW 6	.3750		.6250	0
TW 8	.5000	-.0002	.8750	+0.0008
TW10	.6250	-.0007	1.1250	0
TW12	.7500	-.0003	1.2500	+0.0010
TW16	1.0000	-.0008	1.5625	0
TW20	1.2500	-.0004	2.0000	+0.0012 0
TW24	1.5000	-.0010	2.3750	
TW32	2.0000	-.0004/-0.0012	3.0000	0

### Mounting

TK type TOPBALL is designed to be press fitted into the housing bore. When inserting bushing, however, don't apply excess force nor shock load which may cause permanent damage. For TW type TOPBALL, examples of mouting are shown in Figures D-3~6 and D-8.

### Examples of Mounting

Figures D-3 to D-8 illustrate mounting methods as example.

Figure D-3 Use of Holding Plates

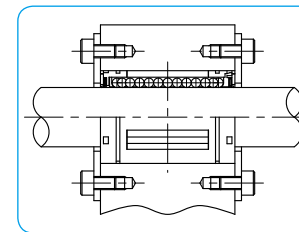

Figure D-4 Clearance Adjustable Type

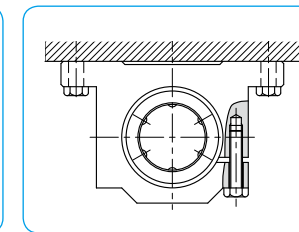

Figure D-5 Use of Retaining Rings

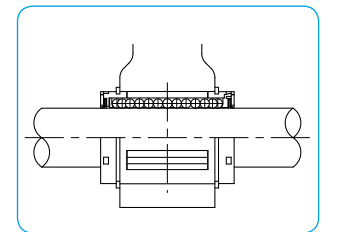

Figure D-6 Open Type

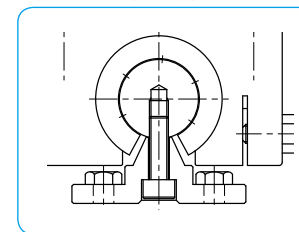

Figure D-7 Press Fit (TK type)

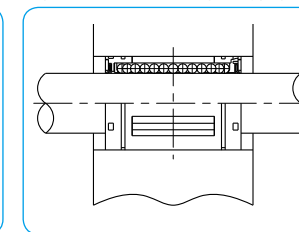
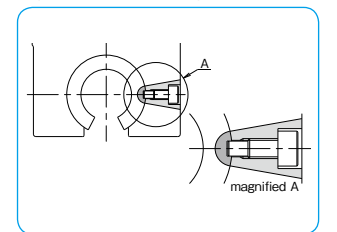

Figure D-8 Pin Fixing



\* SA type support rails are not compatible with the TOPBALL units.

\* Please fix by the pin for open type housing .

## SPECIFICATION

### Anti-Corrosive Type

A special TOPBALL is also available for anti-corrosive requirements. Please specify with a suffix "-SK" for either TOPBALL or TOPBALL Unit part number. The load plates are electroless nickel plated and balls are made of stainless steel.

# TK TYPE

– TOPBALL Metric Type –



### part number structure

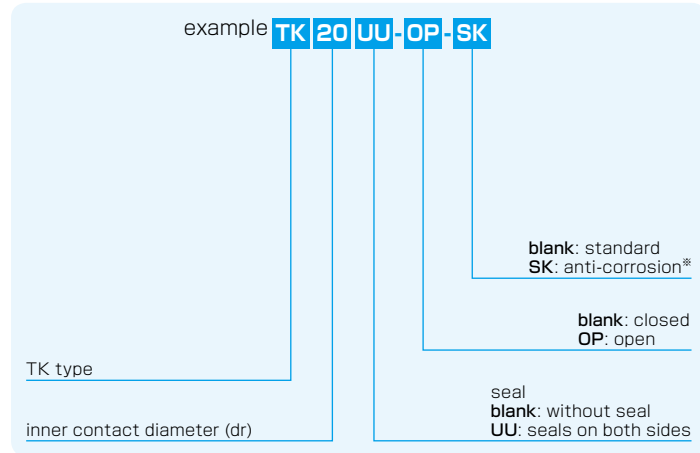

\*For anti-corrosion the load plates are electroless nickel plated with stainless steel balls.

part number						major dimensions				
closed type			open type			dr*	D		L	
number of ball circuits	mass g		number of ball circuits	mass g		tolerance μm	mm	mm	tolerance mm	
TK 8	4	7.3	—	—	—	8	16	25	±0.2	
TK10	5	14	—	—	—	+ 8	19	29		
TK12	5	21	TK12-OP	4	17	12	0	22		32
TK16	5	43	TK16-OP	4	35	16	+ 9	26		36
TK20	6	58	TK20-OP	5	48	20	- 1	32		45
TK25	6	123	TK25-OP	5	103	25	+11	40		58
TK30	6	216	TK30-OP	5	177	30	- 1	47		68
TK40	6	333	TK40-OP	5	275	40	+13	62		80
TK50	6	618	TK50-OP	5	520	50	-2	75		100

\* Based on nominal housing bore

\*\* One-sided seal is also available. Please contact NB for details.

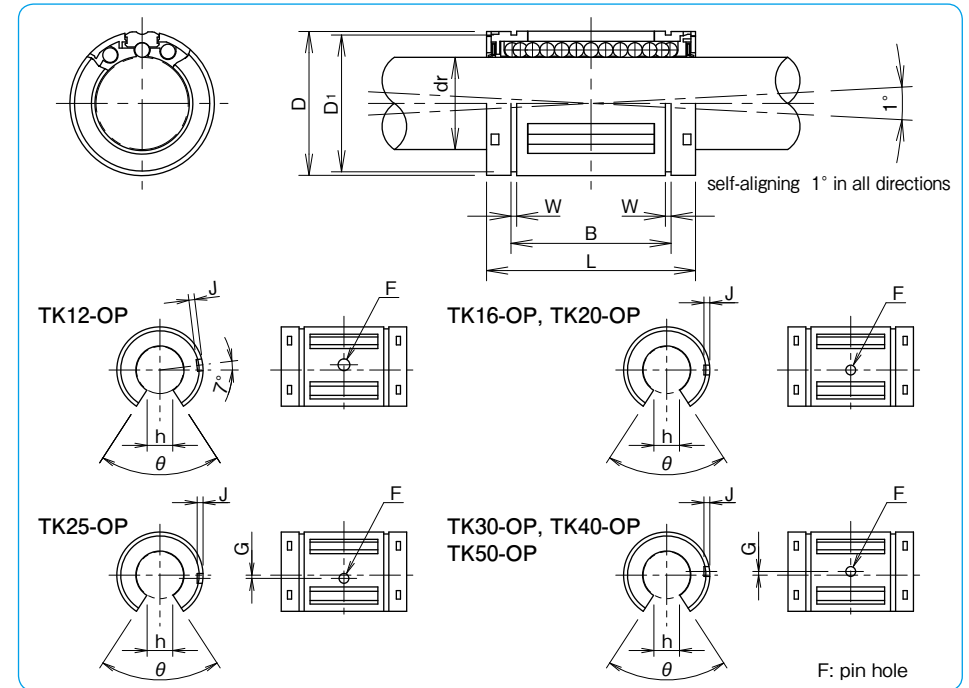

mm	B tolerance mm	W mm	D <sub>1</sub> mm	h mm	θ	open type			basic load rating		shaft diameter mm
						F <sup>H11</sup> mm	G mm	J mm	C N	Co N	
16.5	0	1.1	15.2	—	—	—	—	—	423	534	8
22.0		1.3	18	—	—	—	—	—	750	935	10
22.9		1.3	21	6.5	66°	3	—	0.7	1,020	1,290	12
24.9	1.3	24.9	9	68°	—		1.0	1,250	1,550	16	
31.5	1.6	30.3	9	55°	—		1.0	2,090	2,630	20	
44.1	1.85	37.5	11.5	57°	1.5		1.5	3,780	4,720	25	
52.1	1.85	44.5	14	57°	2		1.7	5,470	6,810	30	
60.6	2.15	59	19.5	56°	1.5		2.4	6,590	8,230	40	
77.6	2.65	72	22.5	54°	5		2.5	2.7	10,800	13,500	50

1N≒0.102kgf

# TW TYPE

- TOPBALL Inch Type -



### part number structure

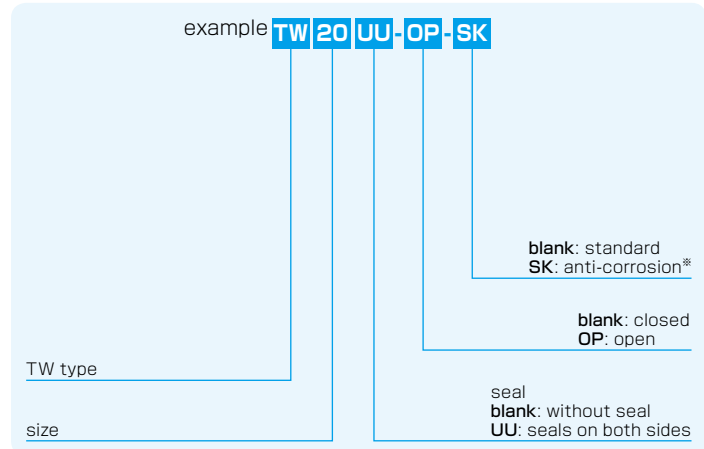

\*For anti-corrosion the load plates are electroless nickel plated with stainless steel balls.

part number						major dimensions					
closed type			open type			dr*		D			L
number of ball circuits	mass lbs		number of ball circuits	mass lbs		inch	tolerance inch	inch	inch	inch	tolerance inch
TW 3	4	.004	—	—	—	.1875	0 -0.005	.3750	.562	±.008	
TW 4	4	.009	—	—	—	.2500		.5000	.750	0	
TW 6	4	.014	—	—	—	.3750		.6250	.875	-.015	
TW 8	4	.043	TW 8-OP	3	.033	.5000		.8750	1.250	0	
TW 10	5	.103	TW 10-OP	4	.083	.6250		1.1250	1.500		
TW 12	6	.123	TW 12-OP	5	.102	.7500		1.2500	1.625		-.020
TW 16	6	.265	TW 16-OP	5	.220	1.0000		1.5625	2.250	0 0/--.025	
TW 20	6	.485	TW 20-OP	5	.419	1.2500		2.0000	2.625		
TW 24	6	.750	TW 24-OP	5	.639	1.5000		2.3750	3.000		0/--.030
TW 32	6	1.411	TW 32-OP	5	1.168	2.0000		0/--.0008	3.0000	4.000	0/--.040

\* Based on nominal housing bore

\*\* Seals are not available on TW3.

\*\*\* One-sided seal is also available. Please contact NB for details.

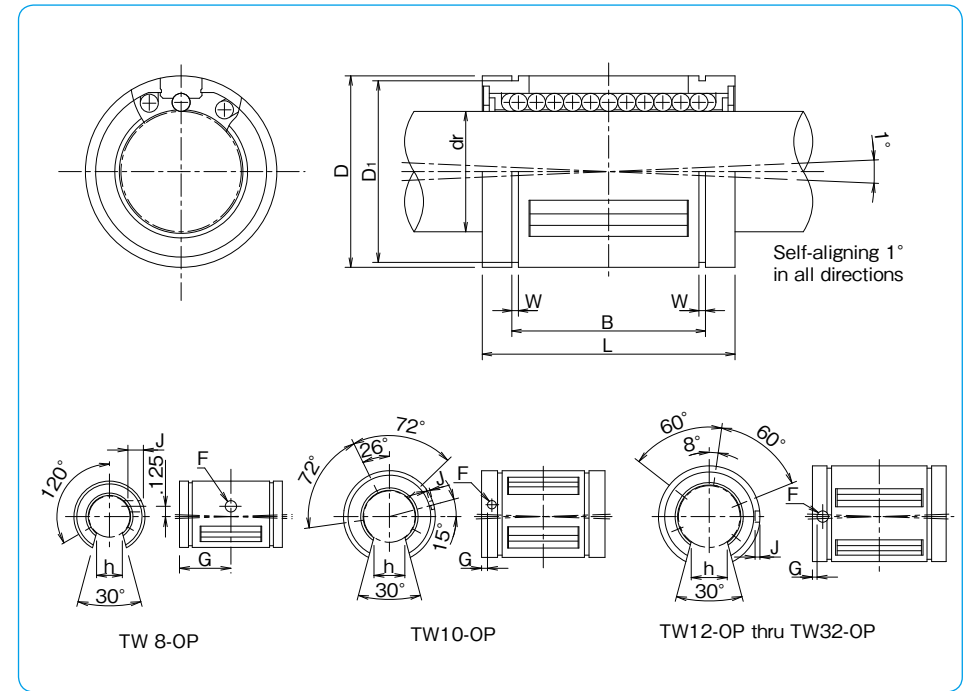

B	W	D <sub>1</sub>	h	open type			basic load rating		nominal shaft diameter	
inch	inch	inch	inch	F	G	J	dynamic C	static Co	inch	
tolerance inch	inch	inch	inch	inch	inch	inch	lbf	lbf	inch	
—	—	—	—	—	—	—	35	47	3/16	
.515	0	.0390	.4687	—	—	—	60	80	1/4	
.703	-.015	.0390	.5880	—	—	—	95	120	3/8	
1.032	0 -0.020	.0459	.8209	.313	.136	.6250	through	230	290	1/2
1.112		.0559	1.0590	.375	.105	.1250	.0390	400	500	5/8
1.272		.0559	1.1760	.438	.136	.1250	.0590	470	590	3/4
1.886		.0679	1.4687	.563	.136	.1250	.0470	850	1,060	1
2.011		0/--.025	.0679	1.8859	.625	.201	.1875	.0900	1,230	1,530
2.422	0/--.030	.0859	2.2389	.750	.201	.1875	.0900	1,480	1,850	1-1/2
3.206	0/--.040	.1029	2.8379	1.000	.265	.3125	through	2,430	3,040	2

1inch=25.4mm

1lbs≐0.454kg

1lbf≐4.448N

# TKA TYPE (Euro Standard)

– Block Type –

## part number structure

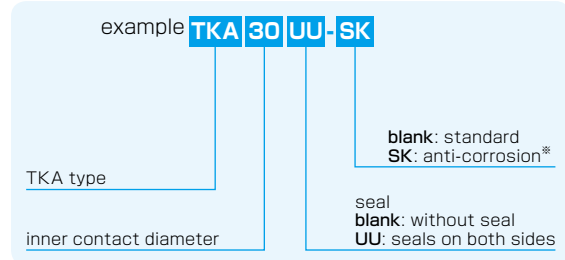

※For anti-corrosion the load plates are electroless nickel plated with stainless steel balls.

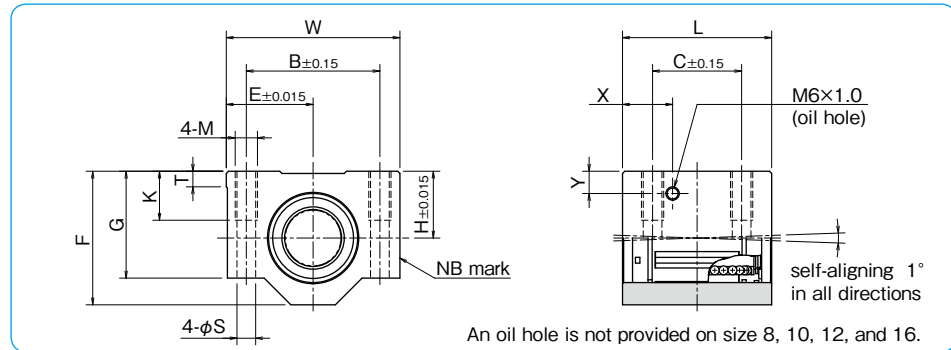

part number	inner contact diameter	major dimensions										mounting dimensions					basic load rating		mass
		H	E	W	L	F	G	T	X	Y	B	C	M	K	S	C	Co		
TKA 8UU	8	15	17.5	35	32	28	22	5	—	—	25	20	M4	9	3.3	423	534	59	
TKA 10UU	10	16	20	40	36	31.5	25	5	—	—	29	20	M5	11	4.3	750	935	90	
TKA 12UU	12	18	21.5	43	39	35	28	5	—	—	32	23	M5	11	4.3	1,020	1,290	116	
TKA 16UU	16	22	26.5	53	43	42	35	5	—	—	40	26	M6	13	5.3	1,250	1,550	205	
TKA 20UU	20	25	30	60	54	50	42	5	19	9	45	32	M8	18	6.6	2,090	2,630	326	
TKA 25UU	25	30	39	78	67	60	48	7	22.5	10	60	40	M10	22	8.4	3,780	4,720	624	
TKA 30UU	30	35	43.5	87	79	70	58	8	26	11.5	68	45	M10	22	8.4	5,470	6,810	980	
TKA 40UU	40	45	54	108	91	90	72	10	26.5	14	86	58	M12	26	10.5	6,590	8,230	1,670	

1N≒0.102kgf

# TKA-W TYPE (Euro Standard)

– Double-Wide Block Type –

## part number structure

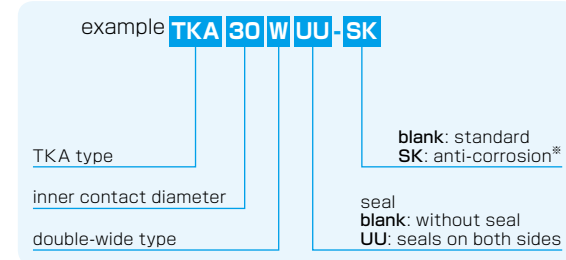

※For anti-corrosion the load plates are electroless nickel plated with stainless steel balls.

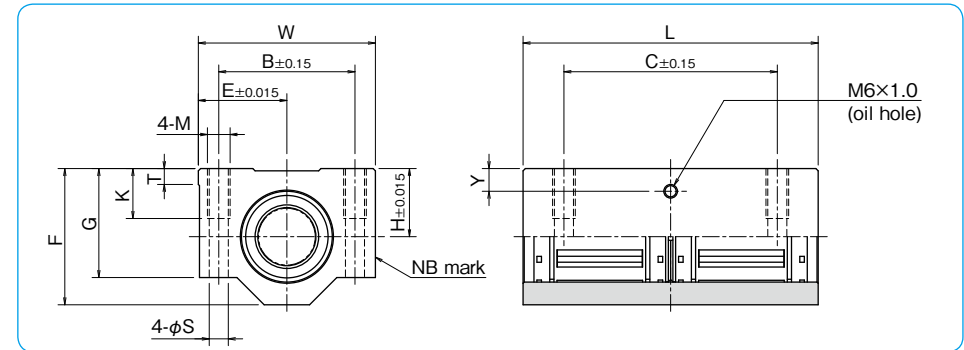

part number	inner contact diameter	major dimensions										mounting dimensions					basic load rating		mass
		H	E	W	L	F	G	T	Y	B	C	M	K	S	C	Co			
TKA 8WUU	8	15	17.5	35	62	28	22	5	6.5	25	50	M4	9	3.3	685	1,068	119		
TKA 10WUU	10	16	20	40	70	31.5	25	5	7	29	52	M5	11	4.3	1,215	1,870	175		
TKA 12WUU	12	18	21.5	43	76	35	28	5	7.5	32	56	M5	11	4.3	1,652	2,580	227		
TKA 16WUU	16	22	26.5	53	84	42	35	5	9.5	40	64	M6	13	5.3	2,025	3,100	390		
TKA 20WUU	20	25	30	60	104	50	42	5	9	45	76	M8	18	6.6	3,390	5,260	630		
TKA 25WUU	25	30	39	78	130	60	48	7	10	60	94	M10	22	8.4	6,120	9,440	1,210		
TKA 30WUU	30	35	43.5	87	152	70	58	8	11.5	68	106	M10	22	8.4	8,860	13,620	1,880		
TKA 40WUU	40	45	54	108	176	90	72	10	14	86	124	M12	26	10.5	10,680	16,460	3,280		

1N≒0.102kgf

# TKE TYPE (Euro Standard)

– Open Block Type –

## part number structure

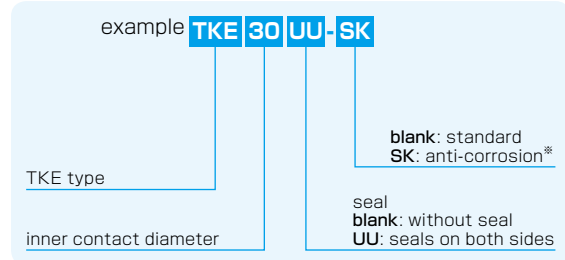

\*For anti-corrosion the load plates are electroless nickel plated with stainless steel balls.

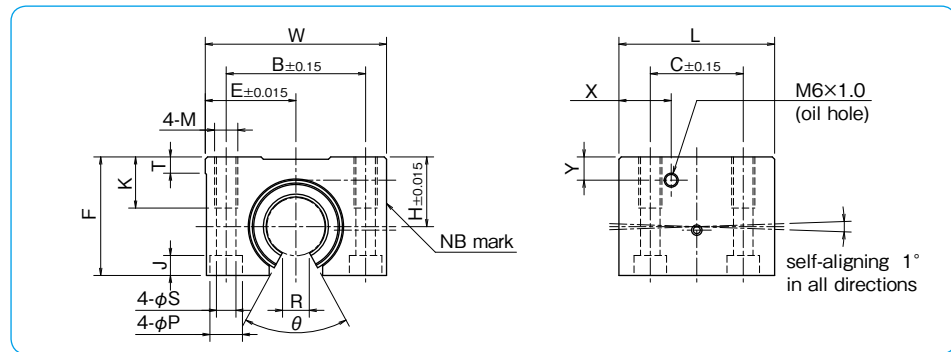

part number	inner contact diameter	major dimensions										mounting dimensions							basic load rating		mass
		H	E	W	L	F	T	R	θ	X	Y	B	C	M	K	S	P	J	C	Co	
TKE12UU	12	18	21.5	43	39	28	5	6.5	66°	14.5	7.5	32	23	M5	11	4.3	8	4.5	1,020	1,290	99
TKE16UU	16	22	26.5	53	43	35	5	9	68°	15.5	9.5	40	26	M6	13	5.3	9.5	5.5	1,250	1,550	175
TKE20UU	20	25	30	60	54	42	5	9	55°	19	9	45	32	M8	18	6.6	11	6.5	2,090	2,630	275
TKE25UU	25	30	39	78	67	51	7	11.5	57°	22.5	10	60	40	M10	22	8.4	14	8.6	3,780	4,720	558
TKE30UU	30	35	43.5	87	79	60	8	14	57°	26	11.5	68	45	M10	22	8.4	14	8.6	5,470	6,810	860
TKE40UU	40	45	54	108	91	77	10	19.5	56°	26.5	14	86	58	M12	26	10.5	17.5	10.8	6,590	8,230	1,490

1N≐0.102kgf

# TKE-W TYPE (Euro Standard)

– Double-Wide Open Block Type –

## part number structure

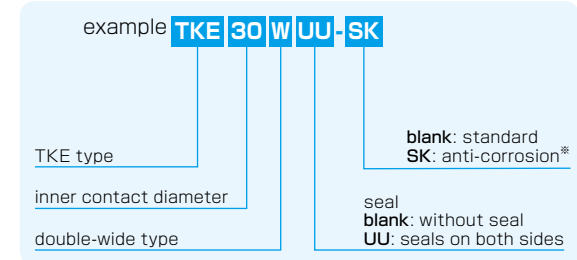

\*For anti-corrosion the load plates are electroless nickel plated with stainless steel balls.

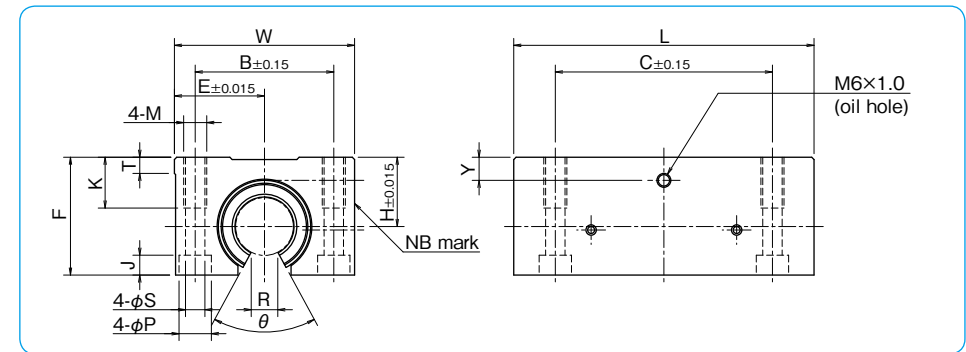

part number	inner contact diameter	major dimensions										mounting dimensions							basic load rating		mass
		H	E	W	L	F	T	R	θ	Y	B	C	M	K	S	P	J	C	Co		
TKE12WUU	12	18	21.5	43	76	28	5	6.5	66°	7.5	32	56	M5	11	4.3	8	4.5	1,652	2,580	190	
TKE16WUU	16	22	26.5	53	84	35	5	9	68°	9.5	40	64	M6	13	5.3	9.5	5.5	2,025	3,100	312	
TKE20WUU	20	25	30	60	104	42	5	9	55°	9	45	76	M8	18	6.6	11	6.5	3,390	5,260	505	
TKE25WUU	25	30	39	78	130	51	7	11.5	57°	10	60	94	M10	22	8.4	14	8.6	6,120	9,440	1,050	
TKE30WUU	30	35	43.5	87	152	60	8	14	57°	11.5	68	106	M10	22	8.4	14	8.6	8,860	13,620	1,630	
TKE40WUU	40	45	54	108	176	77	10	19.5	56°	14	86	124	M12	26	10.5	17.5	10.8	10,680	16,460	2,880	

1N≐0.102kgf

# TKD TYPE (Euro Standard)

– Clearance Adjustable Open Block Type –

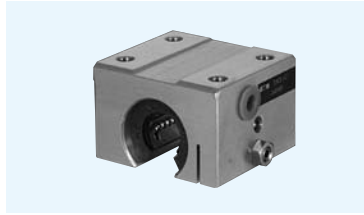

## part number structure

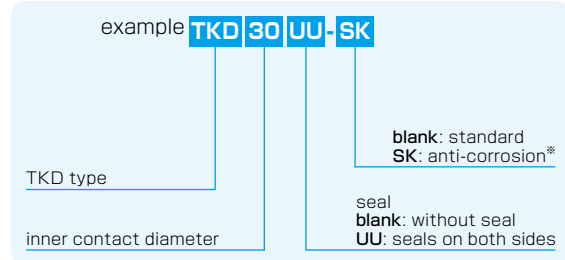

\*For anti-corrosion the load plates are electroless nickel plated with stainless steel balls.

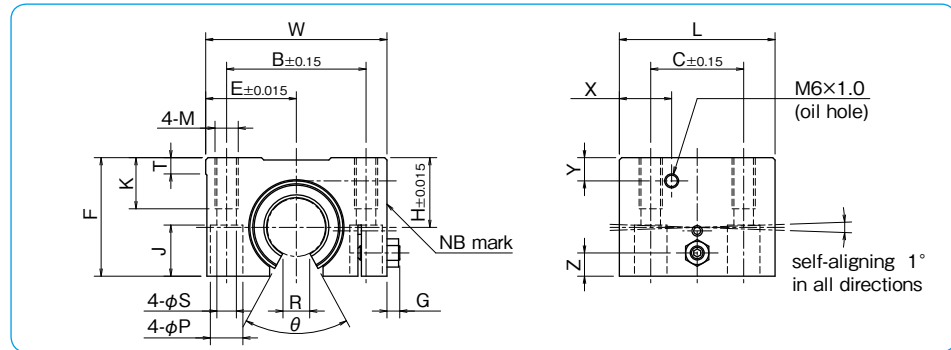

part number	inner contact diameter	major dimensions											mounting dimensions											basic load rating		mass
		H	E	W	L	F	G	Z	T	R	θ	X	Y	B	C	M	K	S	P	J	C	Co	N	Co	N	
TKD12UU	12	18	21.5	43	39	28	3.2	5	5	6.5	66°	14.5	7.5	32	23	M5	11	4.3	8	11.5	1,020	1,290	99			
TKD16UU	16	22	26.5	53	43	35	3.2	6	5	9	68°	15.5	9.5	40	26	M6	13	5.3	9.5	14	1,250	1,550	175			
TKD20UU	20	25	30	60	54	42	4	8	5	9	55°	19	9	45	32	M8	18	6.6	11	18	2,090	2,630	275			
TKD25UU	25	30	39	78	67	51	5.5	10	7	11.5	57°	22.5	10	60	40	M10	22	8.4	14	22	3,780	4,720	558			
TKD30UU	30	35	43.5	87	79	60	5.5	12	8	14	57°	26	11.5	68	45	M10	22	8.4	14	26	5,470	6,810	860			
TKD40UU	40	45	54	108	91	77	5	15	10	19.5	56°	26.5	14	86	58	M12	26	10.5	17.5	33	6,590	8,230	1,490			

1N≐0.102kgf

# TKD-W TYPE (Euro Standard)

– Clearance Adjustable Double-Wide Open Block Type –



## part number structure

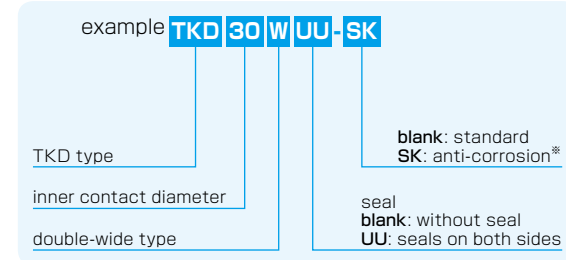

\*For anti-corrosion the load plates are electroless nickel plated with stainless steel balls.

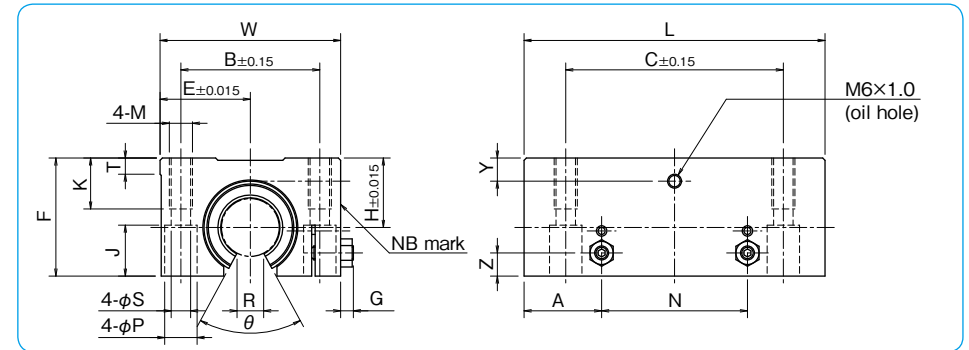

part number	inner contact diameter	major dimensions											mounting dimensions											basic load rating		mass
		H	E	W	L	F	G	Z	A	N	T	R	θ	Y	B	C	M	K	S	P	J	C	Co	N	Co	
TKD12WUU	12	18	21.5	43	76	28	3.2	5	19.5	37	5	6.5	66°	7.5	32	56	M5	11	4.3	8	11.5	1,652	2,580	190		
TKD16WUU	16	22	26.5	53	84	35	3.2	6	21.5	41	5	9	68°	9.5	40	64	M6	13	5.3	9.5	14	2,025	3,100	312		
TKD20WUU	20	25	30	60	104	42	4	8	27	50	5	9	55°	9	45	76	M8	18	6.6	11	18	3,390	5,260	505		
TKD25WUU	25	30	39	78	130	51	5.5	10	33.5	63	7	11.5	57°	10	60	94	M10	22	8.4	14	22	6,120	9,440	1,050		
TKD30WUU	30	35	43.5	87	152	60	5.5	12	39.5	73	8	14	57°	11.5	68	106	M10	22	8.4	14	26	8,860	13,620	1,630		
TKD40WUU	40	45	54	108	176	77	5	15	45.5	85	10	19.5	56°	14	86	124	M12	26	10.5	17.5	33	10,680	16,460	2,880		

1N≐0.102kgf

# TWA TYPE (Inch Standard)

– Block Type –



## part number structure

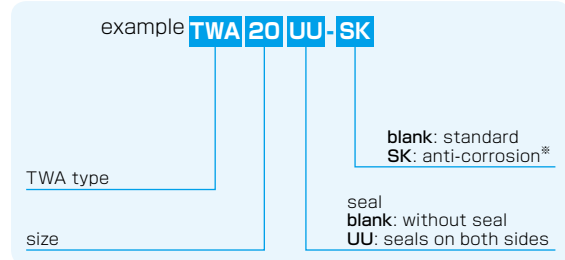

\*For anti-corrosion the load plates are electroless nickel plated with stainless steel balls.

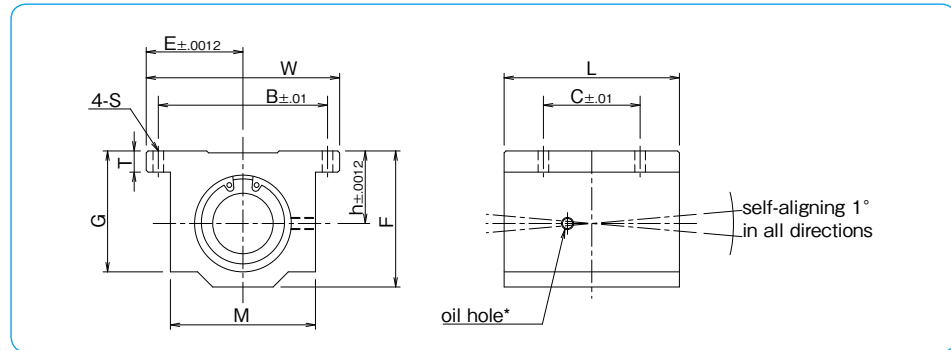

part number	nom. shaft dia.	major dimensions								mounting dimensions			basic load rating		mass
		h	E	W	L	F	T	G	M	B	C	S	dynamic C	static Co	
	inch	inch	inch	inch	inch	inch	inch	inch	inch	inch	inch	inch	lbf	lbf	lbs
TWA 4UU	1/4	.4370	.8125	1.625	1.188	.813	.188	.750	1.000	1.312	.750	.156	60	80	.090
TWA 6UU	3/8	.5000	.8750	1.750	1.313	.938	.188	.875	1.125	1.437	.875	.156	95	120	.120
TWA 8UU	1/2	.6870	1.0000	2.000	1.688	1.250	.250	1.125	1.375	1.688	1.000	.156	230	290	.248
TWA 10UU	5/8	.8750	1.2500	2.500	1.938	1.625	.281	1.437	1.750	2.125	1.125	.188	400	500	.465
TWA 12UU	3/4	.9370	1.3750	2.750	2.063	1.750	.313	1.563	1.875	2.375	1.250	.188	470	590	.553
TWA 16UU	1	1.1870	1.6250	3.250	2.813	2.188	.375	1.938	2.375	2.875	1.750	.219	850	1060	1.200
TWA 20UU	1-1/4	1.5000	2.0000	4.000	3.625	2.813	.438	2.500	3.000	3.500	2.000	.219	1230	1530	2.380
TWA 24UU	1-1/2	1.7500	2.3750	4.750	4.000	3.250	.500	2.875	3.500	4.125	2.500	.281	1480	1850	3.460
TWA 32UU	2	2.1250	3.0000	6.000	5.000	4.063	.625	3.625	4.500	5.250	3.250	.406	2430	3040	6.830

\* Provided with push-in oil fitting for 1/4" to 1/2" sizes. Sizes from 5/8" to 2" offer a 1/4-28 tapped hole with a plug for adding a fitting if desired.

1inch=25.4mm  
1lbs≐0.454kg  
1lbf≐4.448N

# TWA-W TYPE (Inch Standard)

– Double-Wide Block Type –



## part number structure

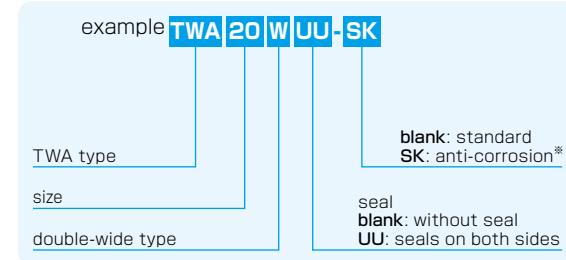

\*For anti-corrosion the load plates are electroless nickel plated with stainless steel balls.

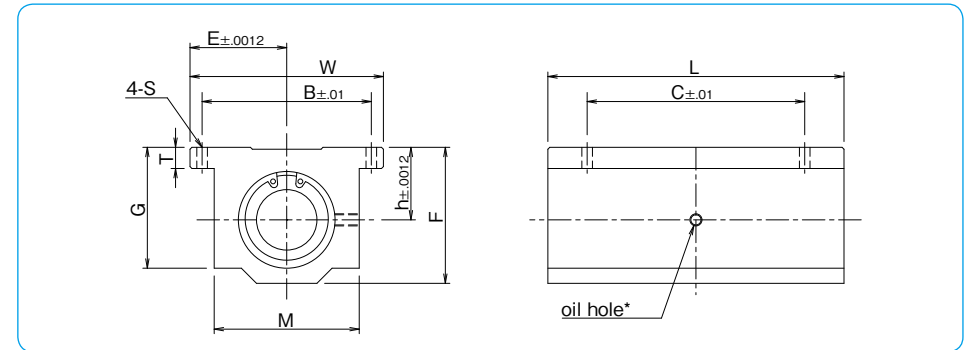

part number	nom. shaft dia.	major dimensions								mounting dimensions			basic load rating		mass
		h	E	W	L	F	T	G	M	B	C	S	dynamic C	static Co	
	inch	inch	inch	inch	inch	inch	inch	inch	inch	inch	inch	inch	lbf	lbf	lbs
TWA 4WUU	1/4	.4370	.8125	1.625	2.500	.813	.188	.750	1.000	1.312	2.000	.156	96	160	.190
TWA 6WUU	3/8	.5000	.8750	1.750	2.750	.938	.188	.875	1.125	1.437	2.250	.156	150	240	.250
TWA 8WUU	1/2	.6870	1.0000	2.000	3.500	1.250	.250	1.125	1.375	1.688	2.500	.156	370	580	.510
TWA 10WUU	5/8	.8750	1.2500	2.500	4.000	1.625	.281	1.437	1.750	2.125	3.000	.188	640	1000	1.000
TWA 12WUU	3/4	.9370	1.3750	2.750	4.500	1.750	.313	1.563	1.875	2.375	3.500	.188	750	1180	1.200
TWA 16WUU	1	1.1870	1.6250	3.250	6.000	2.188	.375	1.938	2.375	2.875	4.500	.219	1360	2120	2.400
TWA 20WUU	1-1/4	1.5000	2.0000	4.000	7.500	2.813	.438	2.500	3.000	3.500	5.500	.219	1970	3060	5.000
TWA 24WUU	1-1/2	1.7500	2.3750	4.750	9.000	3.250	.500	2.875	3.500	4.125	6.500	.281	2370	3700	7.800

\* Provided with push-in oil fitting for 1/4" to 1/2" sizes. Sizes from 5/8" to 1-1/2" offer a 1/4-28 tapped hole with a plug for adding a fitting if desired.

1inch=25.4mm  
1lbs≐0.454kg  
1lbf≐4.448N

# TWJ TYPE (Inch Standard)

— Clearance Adjustable Block Type —

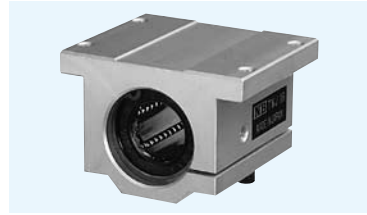

### part number structure

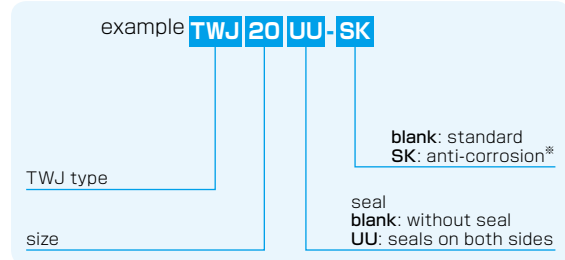

\*For anti-corrosion the load plates are electroless nickel plated with stainless steel balls.

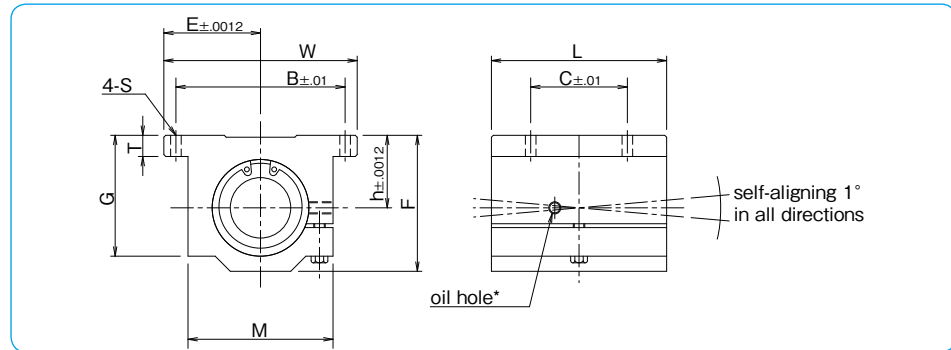

part number	nom. shaft dia.	major dimensions								mounting dimensions			basic load rating		mass
		h	E	W	L	F	T	G	M	B	C	S	dynamic C	static Co	
	inch	inch	inch	inch	inch	inch	inch	inch	inch	inch	inch	inch	lbf	lbf	lbs
TWJ 4UU	1/4	.4370	.8125	1.625	1.188	.813	.188	.750	1.000	1.312	.750	.156	60	80	.090
TWJ 6UU	3/8	.5000	.8750	1.750	1.313	.938	.188	.875	1.125	1.437	.875	.156	95	120	.120
TWJ 8UU	1/2	.6870	1.0000	2.000	1.688	1.250	.250	1.125	1.375	1.688	1.000	.156	230	290	.248
TWJ 10UU	5/8	.8750	1.2500	2.500	1.938	1.625	.281	1.437	1.750	2.125	1.125	.188	400	500	.465
TWJ 12UU	3/4	.9370	1.3750	2.750	2.063	1.750	.313	1.563	1.875	2.375	1.250	.188	470	590	.553
TWJ 16UU	1	1.1870	1.6250	3.250	2.813	2.188	.375	1.938	2.375	2.875	1.750	.219	850	1060	1.200
TWJ 20UU	1-1/4	1.5000	2.0000	4.000	3.625	2.813	.438	2.500	3.000	3.500	2.000	.219	1230	1530	2.380
TWJ 24UU	1-1/2	1.7500	2.3750	4.750	4.000	3.250	.500	2.875	3.500	4.125	2.500	.281	1480	1850	3.460
TWJ 32UU	2	2.1250	3.0000	6.000	5.000	4.063	.625	3.625	4.500	5.250	3.250	.406	2430	3040	6.830

\* Provided with push-in oil fitting for 1/4" to 1/2" size. Sizes from 5/8" to 2" offer a 1/4-28 tapped hole with a plug for adding a fitting if desired.

1inch=25.4mm  
1lbs≐0.454kg  
1lbf≐4.448N

# TWJ-W TYPE (Inch Standard)

— Clearance Adjustable Double-Wide Block Type —



### part number structure

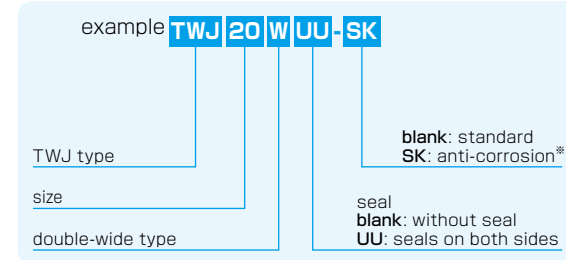

\*For anti-corrosion the load plates are electroless nickel plated with stainless steel balls.

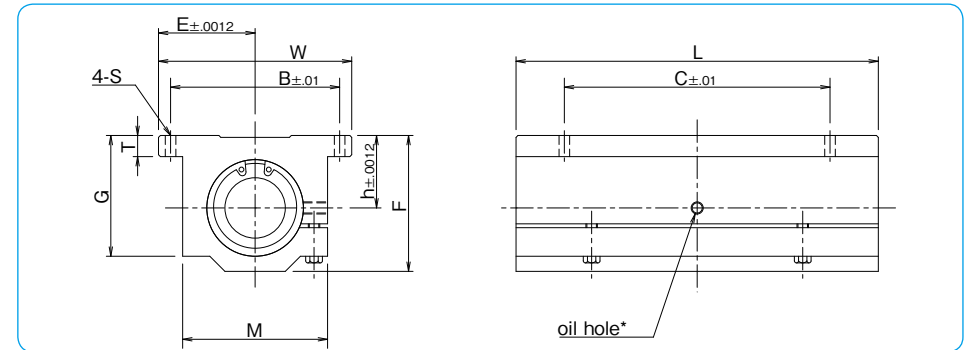

part number	nom. shaft dia.	major dimensions								mounting dimensions			basic load rating		mass
		h	E	W	L	F	T	G	M	B	C	S	dynamic C	static Co	
	inch	inch	inch	inch	inch	inch	inch	inch	inch	inch	inch	inch	lbf	lbf	lbs
TWJ 4WUU	1/4	.4370	.8125	1.625	2.500	.813	.188	.750	1.000	1.312	2.000	.156	96	160	.190
TWJ 6WUU	3/8	.5000	.8750	1.750	2.750	.938	.188	.875	1.125	1.437	2.250	.156	150	240	.250
TWJ 8WUU	1/2	.6870	1.0000	2.000	3.500	1.250	.250	1.125	1.375	1.688	2.500	.156	370	580	.510
TWJ 10WUU	5/8	.8750	1.2500	2.500	4.000	1.625	.281	1.437	1.750	2.125	3.000	.188	640	1000	1.000
TWJ 12WUU	3/4	.9370	1.3750	2.750	4.500	1.750	.313	1.563	1.875	2.375	3.500	.188	750	1180	1.200
TWJ 16WUU	1	1.1870	1.6250	3.250	6.000	2.188	.375	1.938	2.375	2.875	4.500	.219	1360	2120	2.400
TWJ 20WUU	1-1/4	1.5000	2.0000	4.000	7.500	2.813	.438	2.500	3.000	3.500	5.500	.219	1970	3060	5.000
TWJ 24WUU	1-1/2	1.7500	2.3750	4.750	9.000	3.250	.500	2.875	3.500	4.125	6.500	.281	2370	3700	7.800

\* Provided with push-in oil fitting for 1/4" to 1/2" size. Sizes from 5/8" to 2" offer a 1/4-28 tapped hole with a plug for adding a fitting if desired.

1inch=25.4mm  
1lbs≐0.454kg  
1lbf≐4.448N

# TWD TYPE (Inch Standard)

– Open Block Type –

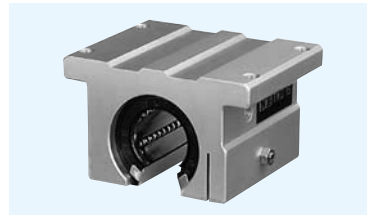

## part number structure

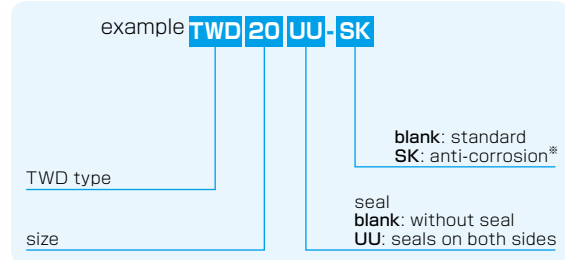

※For anti-corrosion the load plates are electroless nickel plated with stainless steel balls.

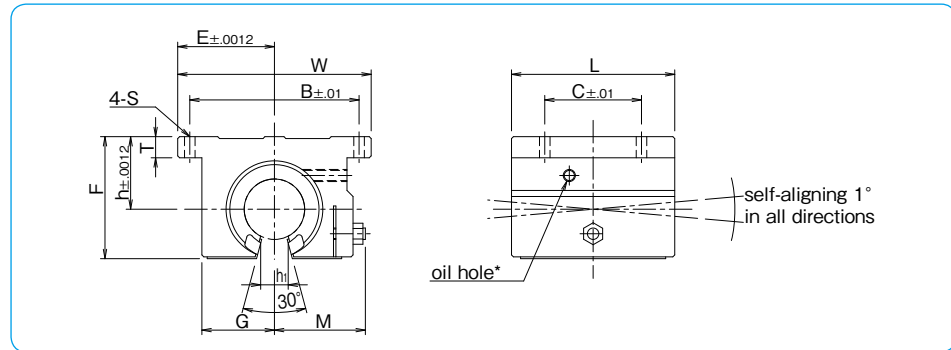

part number	nom. shaft dia. inch	major dimensions										mounting dimensions			basic load rating		mass lbs
		h	E	W	L	F	T	G	M	h <sub>1</sub>	B	C	S	dynamic C lbf	static Co lbf		
TWD 8UU	1/2	.6870	1.000	2.000	1.500	1.100	.250	.688	.86	.260	1.688	1.000	.156	230	290	.188	
TWD 10UU	5/8	.8750	1.2500	2.500	1.750	1.405	.281	.875	1.06	.319	2.125	1.125	.188	400	500	.365	
TWD 12UU	3/4	.9370	1.3750	2.750	1.875	1.535	.315	.937	1.12	.386	2.375	1.250	.188	470	590	.452	
TWD 16UU	1	1.1870	1.6250	3.250	2.625	1.975	.375	1.188	1.40	.512	2.875	1.750	.218	850	1060	1.010	
TWD 20UU	1-1/4	1.5000	2.0000	4.000	3.375	2.485	.437	1.500	1.88	.596	3.500	2.000	.218	1230	1530	1.980	
TWD 24UU	1-1/2	1.7500	2.3750	4.750	3.750	2.910	.500	1.750	2.12	.681	4.125	2.500	.281	1480	1850	2.950	
TWD 32UU	2	2.1250	3.0000	6.000	4.750	3.660	.625	2.250	2.70	.933	5.250	3.250	.406	2430	3040	5.840	

\* Provided with push-in oil fitting for 1/4" to 1/2" size. Sizes from 5/8" to 2" offer a 1/4-28 tapped hole with a plug for adding a fitting if desired.

1inch=25.4mm  
1lbs≐0.454kg  
1lbf≐4.448N

# TWD-W TYPE (Inch Standard)

– Double-Wide Open Block Type –

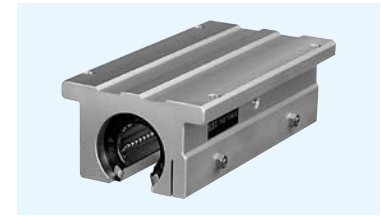

## part number structure

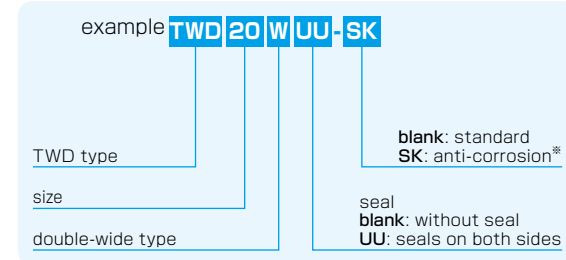

※For anti-corrosion the load plates are electroless nickel plated with stainless steel balls.

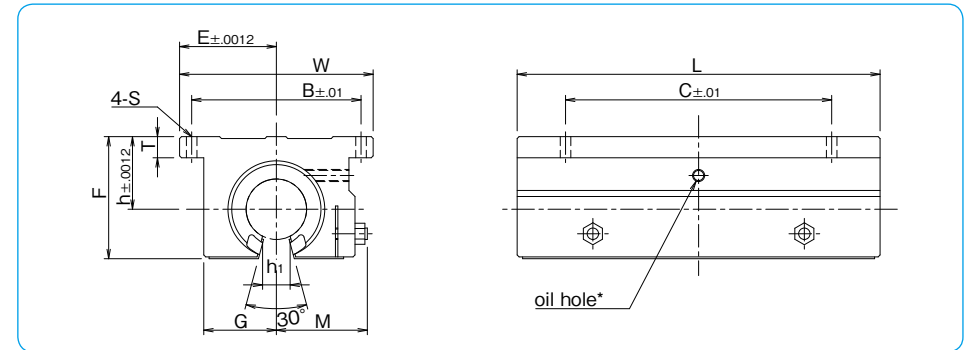

part number	nom. shaft dia. inch	major dimensions										mounting dimensions			basic load rating		mass lbs
		h	E	W	L	F	T	G	M	h <sub>1</sub>	B	C	S	dynamic C lbf	static Co lbf		
TWD 8WUU	1/2	.6870	1.000	2.000	3.500	1.100	.250	.688	.86	.260	1.688	2.500	.156	370	580	.400	
TWD 10WUU	5/8	.8750	1.2500	2.500	4.000	1.405	.281	.875	1.06	.319	2.125	3.000	.188	640	1000	.800	
TWD 12WUU	3/4	.9370	1.3750	2.750	4.500	1.535	.315	.937	1.12	.386	2.375	3.500	.188	750	1180	1.000	
TWD 16WUU	1	1.1870	1.6250	3.250	6.000	1.975	.375	1.188	1.40	.512	2.875	4.500	.218	1360	2120	2.000	
TWD 20WUU	1-1/4	1.5000	2.0000	4.000	7.500	2.485	.437	1.500	1.88	.569	3.500	5.500	.218	1970	3060	4.200	
TWD 24WUU	1-1/2	1.7500	2.3750	4.750	9.000	2.910	.500	1.750	2.12	.681	4.125	6.500	.281	2370	3700	6.700	

\* Provided with push-in oil fitting for 1/4" to 1/2" size. Sizes from 5/8" to 2" offer a 1/4-28 tapped hole with a plug for adding a fitting if desired.

1inch=25.4mm  
1lbs≐0.454kg  
1lbf≐4.448N