

STROKE BUSH

SLIDE ROTARY

BUSH

STROKE BUSH

The NB stroke bush is a linear and rotational motion mechanism utilizing the rotational motion of ball elements between an outer cylinder and a shaft. It is compact and can withstand high loading. The retainer is made of a light metal alloy with high wear resistance. Smooth motion is achieved under high-speed and high-acceleration conditions.

Although the linear motion is limited to a specific stroke length, the combined rotation and stroke motion is achieved with very little frictional resistance. The NB stroke bush can be conveniently used in a variety of applications.

STRUCTURE AND ADVANTAGES

The retainer in the NB stroke bush positions the ball elements in a zigzag arrangement. The inner surface of the outer cylinder is finished by precision grinding, resulting in smooth motion of the ball elements. Each of the ball elements is held in a separate hole and smooth motion is achieved for both rotational motion and linear motion. The retainer moves half the length of the linear motion, therefore, the stroke length is limited to approximately twice the length the retainer can travel within the outer cylinder. The actual stroke should be limited to 80% of the maximum stroke as listed in the dimension tables.

High Precision

High-carbon chromium bearing steel is used for the outer cylinder. It is heat treated and ground to achieve high rigidity and accuracy.

Ease of Mounting and Replacement

The highly accurate fabrication of the NB stroke bush results in uniform dimensions, facilitating parts replacement and housing fabrication.

Light Weight and Space Saving

The use of an aluminum alloy for the retainer and the thin-wall outer cylinder makes the NB stroke bush light weight and compact.

Lubrication

One lubrication hole is provided on each oil groove of the outer cylinder, making it easy to lubricate the SR stroke bush.

Figure E-1 Structure of SR Stroke Bush

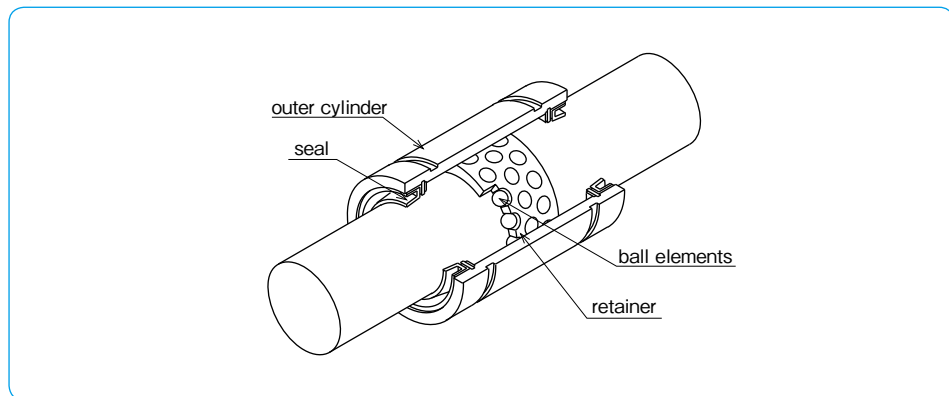

ACCURACY

The accuracies of the SR stroke bush are stated in the dimension tables. Since the outer cylinder deforms due to tension from the retaining ring, the dimension of the outer cylinder is an average value at points P, where calculated using the following equation:

$$W = 4 + L/8$$

W: the distance from the end of the outer cylinder to measurement point P
L: the length of the outer cylinder

FIT

The fits generally used between the shaft and the housing are listed in Table E-1. The inner contact diameters of the SR stroke bush are listed in the dimension tables. The shaft diameter tolerance should be selected to achieve the desired amount of radial clearance (see Table E-2). Please pay attention that high-speed linear motion can cause the retainer to slip due to inertial force.

Table E-1

normal operating condition		vertical use or highly accurate case	
shaft	housing	shaft	housing
k5,m5	H6,H7	n5,p6	J6,J7

RATED LOAD AND RATED LIFE

The relationship between the rated load and life of the stroke bush is expressed as follows:

$$L = \left(\frac{f_H \cdot f_T \cdot f_C \cdot C}{f_W \cdot P} \right)^3$$

L: rated life (10⁶ rotations) f_H: hardness coefficient
f_T: temperature coefficient f_C: contact coefficient
f_W: applied load coefficient
C: basic dynamic load rating (N)
P: applied load (N)
※Refer to page Eng-5 for the coefficients.

ALLOWABLE SPEED FOR COMBINED ROTATION AND STROKE MOTION

The allowable speed for combined rotation and stroke motion is obtained from the following equation:

$$DN \geq dm \cdot n + 10 \cdot S \cdot n_1$$

Figure E-2 Outer Cylinder Measurement Points

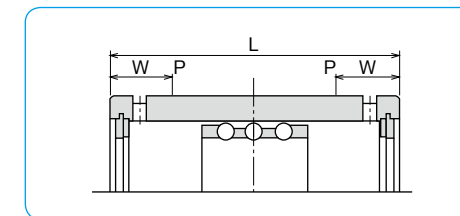

Table E-2 Radial Clearance Negative Limit

part number	limit (μm)
6	- 2
8~10	- 3
12~16	- 4
20~30	- 5
35~50	- 6
60~80	- 8
100	-10

●For combined rotation and stroke motion

$$L_h = \frac{10^6 \cdot L}{60 \sqrt{(dm \cdot n)^2 + (10 \cdot S \cdot n_1)^2}} / dm$$

●For stroke motion

$$L_h = \frac{10^6 \cdot L}{600 \cdot S \cdot n_1 / (\pi \cdot dm)}$$

L_h: life time (hr) S: stroke length (mm)
n: revolutions per min. (rpm)
n₁: number of cycles per minute (cpm)
dm: ball pitch diameter (mm) ≈ 1.15 dr

The value of DN is given as follows depending on the lubrication method.

for oil lubrication	DN=600,000
for grease lubrication	DN=300,000

note: n ≤ 5,000 S · n₁ ≤ 50,000

SR TYPE



part number structure

example **SR 20**

SR type

inner contact diameter (dr)

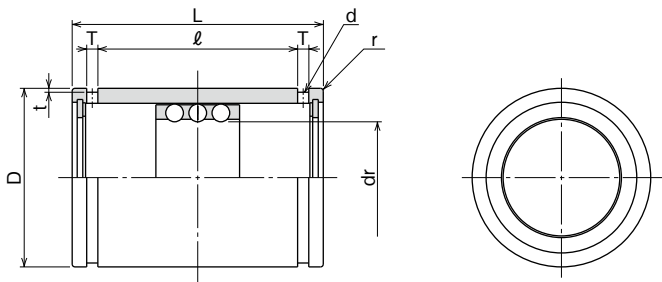

SR-UU TYPE



part number structure

example **SR 20 UU**

SR type

inner contact diameter (dr)

seals on both sides

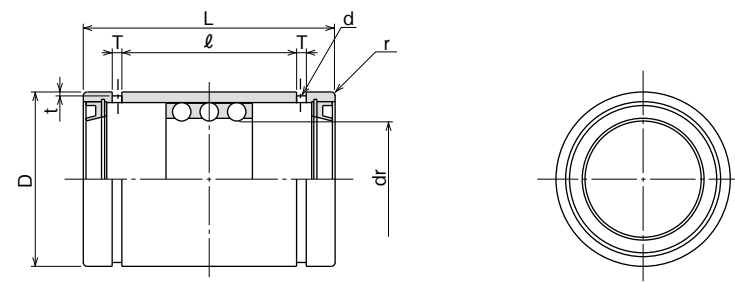

part number	maximum stroke mm	number of rows	dr		D		major dimensions					basic load rating		mass g	
			mm	tolerance μm	mm	tolerance μm	L	ℓ	T	t	d	r	dynamic C N		static Co N
SR 6	20	3	6	+22	12	0	20	11.3	1.1	0.5	1	0.5	216	147	8.9
SR 8	24	3	8	+13	15	-11	24	17.1	1.5	0.5	1.2	0.5	343	245	15.6
SR 10	30	3	10	+19	19	0	30	22.7	1.5	0.5	1.2	0.5	637	461	28.8
SR 12	32	3	12	+27	23	-13	32	24.5	1.5	0.5	1.2	0.5	1,070	813	42
SR 16	40	3	16	+16	28	0	37	29.1	1.5	0.7	1.3	0.5	1,180	990	71
SR 20	50	3	20	+33	32	0	45	35.8	2	0.7	1.5	0.5	1,260	1,170	99
SR 25	50	3	25	+20	37	-16	45	35.8	2	0.7	1.6	1	1,330	1,330	117
SR 30	82	3	30	+45	45	0	65	53.5	2.5	1	2	1	2,990	3,140	205
SR 35	92	3	35	+52	52	0	70	58.5	2.5	1	2	1.5	3,140	3,530	329
SR 40	108	3	40	+41	60	0	80	68.3	2.5	1	2	1.5	4,120	4,800	516
SR 50	138	3	50	+25	72	-19	100	86.4	3	1	2.5	1.5	5,540	6,910	827
SR 60	138	3	60	+49	85	0	100	86.4	3	1	2.5	2	5,980	8,230	1,240
SR 80	132	3	80	+30	110	-22	100	86	3	1.5	2.5	2	7,840	12,200	2,050
SR100	132	3	100	+58/+36	130	0/-25	100	86	3	1.5	2.5	2	8,430	14,700	2,440

1N≅0.102kgf

part number	maximum stroke mm	number of rows	dr		D		major dimensions					basic load rating		mass g	
			mm	tolerance μm	mm	tolerance μm	L	ℓ	T	t	d	r	dynamic C N		static Co N
SR 8UU	14	3	8	+22	15	0/-11	24	12.3	1.5	0.5	1.2	0.5	343	245	15.6
SR 10UU	16	3	10	+13	19	0	30	15.5	1.5	0.5	1.2	0.5	637	461	28.8
SR 12UU	17	3	12	+27	23	-13	32	17.1	1.5	0.5	1.2	0.5	1,070	813	42
SR 16UU	24	3	16	+16	28	0	37	21.1	1.5	0.7	1.3	0.5	1,180	990	71
SR 20UU	32	3	20	+33	32	-16	45	26.8	2	0.7	1.5	0.5	1,260	1,170	99
SR 25UU	32	3	25	+20	37	0	45	26.8	2	0.7	1.6	1	1,330	1,330	117
SR 30UU	65	3	30	+45	45	-16	65	45.1	2.5	1	2	1	2,990	3,140	205
SR 35UU	75	3	35	+52	52	0	70	50.1	2.5	1	2	1.5	3,140	3,530	329
SR 40UU	91	3	40	+41	60	0	80	59.9	2.5	1	2	1.5	4,120	4,800	516
SR 50UU	120	3	50	+25	72	-19	100	77.4	3	1	2.5	1.5	5,540	6,910	827
SR 60UU	120	3	60	+49	85	0	100	77.4	3	1	2.5	2	5,980	8,230	1,240
SR 80UU	114	3	80	+30	110	-22	100	77	3	1.5	2.5	2	7,840	12,200	2,050
SR100UU	114	3	100	+58/+36	130	0/-25	100	77	3	1.5	2.5	2	8,430	14,700	2,440

1N≅0.102kgf

SR-B TYPE



part number structure

example **SR 20 B**

SR type
inner contact diameter (dr)
double retainer

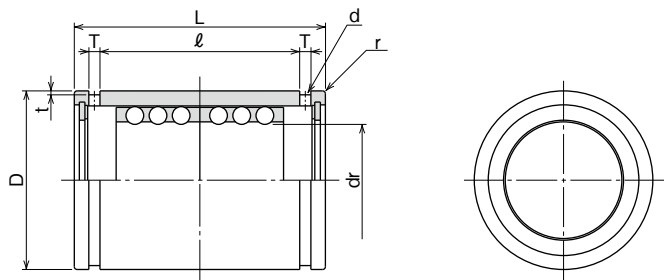

part number	maximum stroke mm	number of rows	major dimensions										basic load rating		mass g	
			dr mm	tolerance μm	D mm	tolerance μm	L mm	tolerance mm	ℓ mm	T mm	t mm	d mm	r mm	C N		Co N
SR 8B	8	6	8	+22	15	0/-11	24	0	17.1	1.5	0.5	1.2	0.5	549	490	16.8
SR 10B	8	6	10	+13	19	0	30	0	22.7	1.5	0.5	1.2	0.5	1,030	931	31.2
SR 12B	8	6	12	+27	23	-13	32	-0.2	24.5	1.5	0.5	1.2	0.5	1,720	1,630	46
SR 16B	16	6	16	+16	28	0	37	0	29.1	1.5	0.7	1.3	0.5	1,910	1,980	75
SR 20B	20	6	20	+33	32	0	45	0	35.8	2	0.7	1.5	0.5	2,060	2,320	106
SR 25B	20	6	25	+20	37	-16	45	0	35.8	2	0.7	1.6	1	2,170	2,670	125
SR 30B	44	6	30	+33	45	0	65	0	53.5	2.5	1	2	1	4,800	6,270	220
SR 35B	54	6	35	+41	52	0	70	0	58.5	2.5	1	2	1.5	5,050	7,060	346
SR 40B	66	6	40	+25	60	-19	80	-0.3	68.3	2.5	1	2	1.5	6,710	9,560	540
SR 50B	88	6	50	+30	72	0	100	0	86.4	3	1	2.5	1.5	8,970	13,800	862
SR 60B	88	6	60	+49	85	0	100	0	86.4	3	1	2.5	2	9,700	16,500	1,290
SR 80B	76	6	80	+30	110	-22	100	0	86	3	1.5	2.5	2	12,700	24,300	2,110
SR100B	76	6	100	+58/+36	130	0/-25	100	-0.4	86	3	1.5	2.5	2	13,700	29,400	2,520

1N≒0.102kgf

SR-BUU TYPE



part number structure

example **SR 30 B UU**

SR type
inner contact diameter (dr)
double retainer
seals on both sides

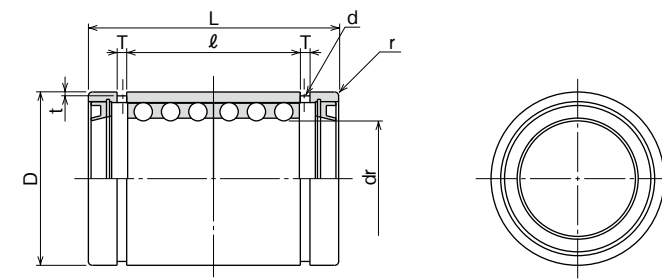

part number	maximum stroke mm	number of rows	major dimensions										basic load rating		mass g	
			dr mm	tolerance μm	D mm	tolerance μm	L mm	tolerance mm	ℓ mm	T mm	t mm	d mm	r mm	C N		Co N
SR 30BUU	27	6	30	+33/+20	45	0/-16	65	0	45.1	2.5	1	2	1	4,800	6,270	220
SR 35BUU	37	6	35	+41	52	0	70	0	50.1	2.5	1	2	1.5	5,050	7,060	346
SR 40BUU	49	6	40	+25	60	-19	80	-0.3	59.9	2.5	1	2	1.5	6,710	9,560	540
SR 50BUU	70	6	50	+30	72	0	100	0	77.4	3	1	2.5	1.5	8,970	13,800	862
SR 60BUU	70	6	60	+49	85	0	100	0	77.4	3	1	2.5	2	9,700	16,500	1,290
SR 80BUU	58	6	80	+30	110	-22	100	0	77	3	1.5	2.5	2	12,700	24,300	2,110
SR100BUU	58	6	100	+58/+36	130	0/-25	100	-0.4	77	3	1.5	2.5	2	13,700	29,400	2,520

1N≒0.102kgf

SLIDE ROTARY BUSH SRE SERIES

The NB Slide Rotary Bush SRE Series provides rotary and linear motion functions. Linear motion with unlimited stroke and rotary motion are merged into a single bush resulting in great space saving compared with a combination of any conventional bearings. There are three types; standard, flange, and unit type with sizes ranging from 6 to 40.

STRUCTURE AND ADVANTAGES

NB Slide Rotary Bush features a special retainer fitted into cylindrical steel outer cylinder and is designed to guide steel balls for smooth circulation in its retainer. The retainer is also designed to rotate freely towards radial direction and offers smooth linear and rotary motions.

Smooth Operation

The inner surface of the outer cylinder allows smooth operation of linear and rotary motions while maintaining a uniform load distribution.

High Load Capacity

The use of comparatively large diameter steel balls enhances the load capacity.

Smooth Rotation

The positioning of the steel balls in a cylindrical formation inside the retainer enables a smooth rotational motion regardless of the installation direction.

Complete Interchangeability

NB Slide Rotary series is completely interchangeable with SM type Slide Bush, SMK type Flanged Slide Bush and SMA(W) type, AK(W) type and SMP type.

Figure E-3 Structure of Slide Rotary Bush SRE type

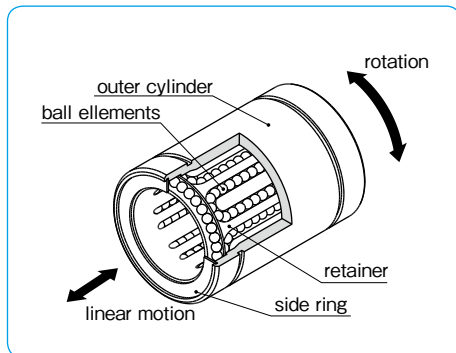

RATED LIFE AND LOAD RATING

The rated life and load rating are defined as follows.

Rated Life

When a group of slide rotary bearings of the same type are used under the same conditions, the rated life is defined as the total number of rotations made without causing flaking by 90% of the bearings.

Basic Dynamic Load Rating

The basic dynamic load rating is defined as the load with a constant magnitude and direction at which a rated life of 10^6 rotations can be achieved.

Basic Static Load Rating

The basic static load rating is defined as the load with a constant direction that would result in a certain contact stress at the mid-point of the rolling element and tracking surface that are experiencing the maximum stress.

Equation (1) gives the relation between the applied load and the rated life of the slide rotary bush.

$$L = \left(\frac{f_H \cdot f_T \cdot f_C}{f_W} \cdot \frac{C}{P} \right)^3 \dots \dots \dots (1)$$

L: rated life (10^6 rotations) f_H : hardness coefficient
 f_T : temperature coefficient f_C : contact coefficient
 f_W : applied load coefficient C: basic dynamic load rating (N)
 P: applied load (N)
 ※Refer to page Eng-5 for the coefficients.

Since the slide rotary bush is used in applications with combined linear and rotary motions, the life time is obtained using Equations (2) and (3).

●When linear and rotary motions are combined

$$L_h = \frac{10^6 \cdot L}{60 \sqrt{(dm \cdot n)^2 + (10 \cdot S \cdot n_1)^2} / dm} \dots \dots (2)$$

●When only linear motion is involved

$$L_h = \frac{10^6 \cdot L}{600 \cdot S \cdot n_1 / (\pi \cdot dm)} \dots \dots \dots (3)$$

L_h : life time (hr) S: stroke length (mm) n: revolutions per minute (rpm) n_1 : number of cycles per minute (cpm)
 dm : ball pitch diameter (mm) $\approx 1.15dr$ (dr is the inner contact diameter of the SRE series)

Calculation Example

The life of SRE20 type NB slide rotary bush is calculated based on the following conditions.

- Conditions
 - Motion: Linear and rotational combined Load: P=30N Stroke: S=200mm
 - Revolutions per minute: n=15rpm Number of cycles per minute: $n_1=10$ cpm
 - Shaft surface hardness: greater than 58 HRC
 - Operating temperature: room temperature Other: single shaft with single bush

- Calculation
 - Basic dynamic load rating: C=647 N
 - Based on the above conditions, the life is calculated using the following coefficient values.
 - Hardness coefficient $f_H=1$, Temperature coefficient $f_T=1$, Contact coefficient $f_C=1$
 - Applied load coefficient, $f_W=1.5$

Rated life

$$L = \left(\frac{f_H \cdot f_T \cdot f_C}{f_W} \cdot \frac{C}{P} \right)^3$$

$$= \left(\frac{1 \times 1 \times 1}{1.5} \cdot \frac{647}{30} \right)^3 = 2,972 \text{ (} 10^6 \text{ rotations)}$$

Life (in hours)

$$L_h = \frac{10^6 \cdot L}{60 \sqrt{(dm \cdot n)^2 + (10 \cdot S \cdot n_1)^2} / dm}$$

$$= \frac{10^6 \times 2,975}{60 \sqrt{(1.15 \times 20 \times 15)^2 + (10 \times 200 \times 10)^2} / (1.15 \times 20)}$$

$$= 56,900 \text{ (h)}$$

APPLICATION EXAMPLES

Application Example 1 Vertical Shaft Robot Arm

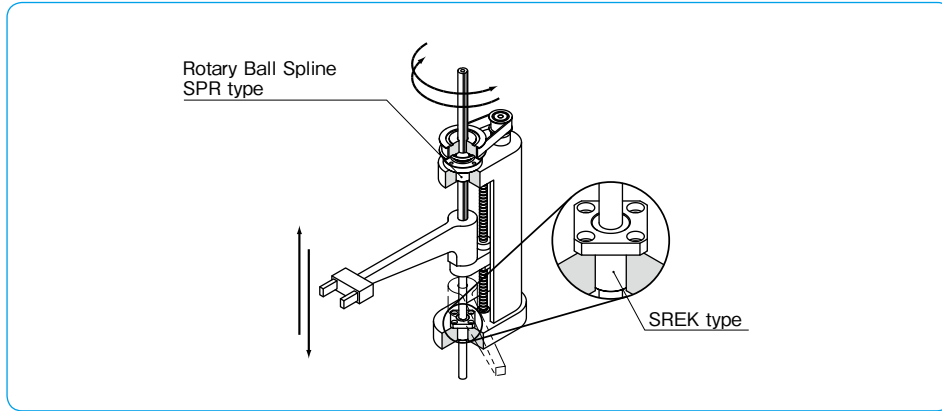

Application Example 2 Multiple Gearing Idler

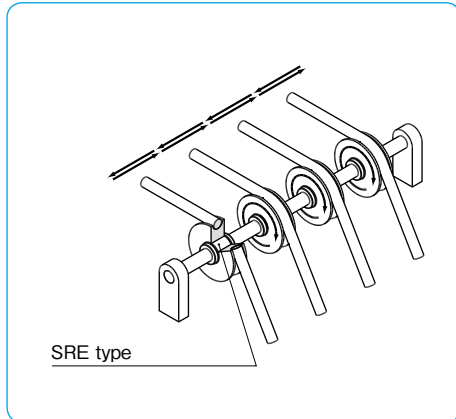

Application Example 4 Turntable

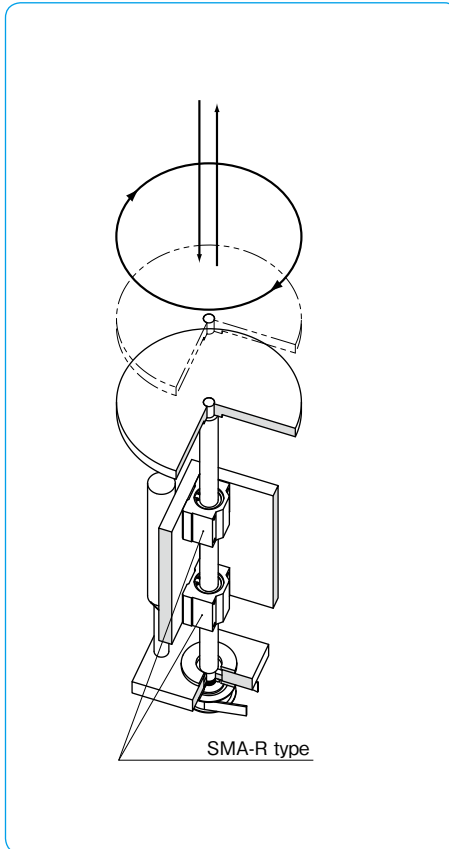

Application Example 3 Tool Changer

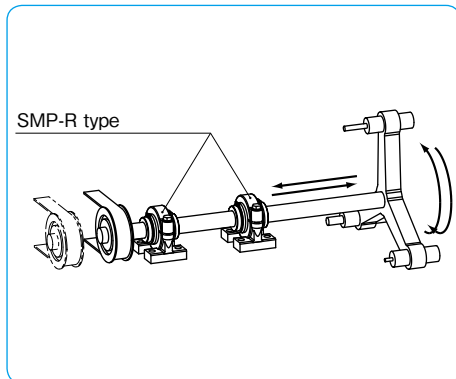

USE AND HANDLING PRECAUTIONS

● Shaft

Since the ball elements rotate on the shaft surface in the SRE type slide rotary bush, the accuracy and hardness of the shaft are important factors.

Outer Diameter: A tolerance of g6 is recommended for smooth operation.

Hardness: A hardness of greater than 58HRC is recommended for long life. If the hardness is less than 58 HRC, the life is calibrated using the hardness coefficient.

Surface Roughness: A roughness of less than 0.4Ra is recommended.

● Housing

An inner diameter tolerance of H7 is recommended for housing.

● Lubrication

Lubrication is needed (1) to prevent heat fusing by reducing friction between the rolling elements and the tracking surface, (2) to reduce wear of the structural elements, and (3) to prevent rusting.

Lubrication affects both the performance and life of the bush. A lubrication method and a lubrication agent appropriate to the operating conditions should be selected. For oil lubrication, turbine oil (ISO standard VG32-68) is recommended. For grease lubrication, lithium soap based grease No. 2 is recommended. The replenishment interval depends on the operating conditions.

● Dust Prevention

Dust and other contaminants affect the bush's lifetime and accuracy. Appropriate prevention methods are thus important.

● Operating Temperature Range

The operating temperature is ranging from -20°C to 110°C. In case of operation at a temperature outside this range, please contact NB.

● Retainer Material

The standard material of SRE Retainer is copper alloy. When requiring other material, please contact NB.

FELT SEAL

A felt seal FLM strengthens lubrication characteristics and extends relubrication period of the slide rotary bush.

Figure E-4 Felt Seal

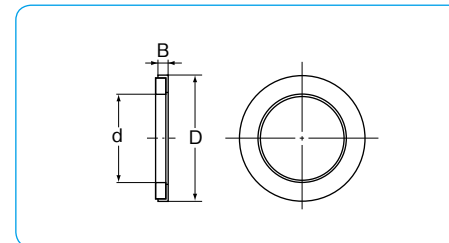

Installation

The felt seal does not work as a retaining ring. Figure E-5 shows how to install the felt seal.

Table E-3 Felt Seal Dimensions

part number	major dimensions (mm)			applicable slide rotary bush
	d	D	B	
FLM 6	6	12	2	SRE 6
FLM 8	8	15	2	SRE 8
FLM 10	10	19	3	SRE 10
FLM 12	12	21	3	SRE 12
FLM 13	13	23	3	SRE 13
FLM 16	16	28	4	SRE 16
FLM 20	20	32	4	SRE 20
FLM 25	25	40	5	SRE 25
FLM 30	30	45	5	SRE 30
FLM 40	40	60	5	SRE 40

Figure E-5 Example of Installation

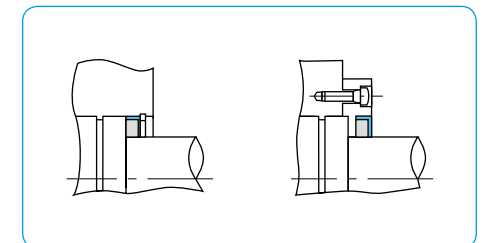

SRE TYPE



part number structure

example **SRE 25**

SRE type

inner contact diameter (dr)

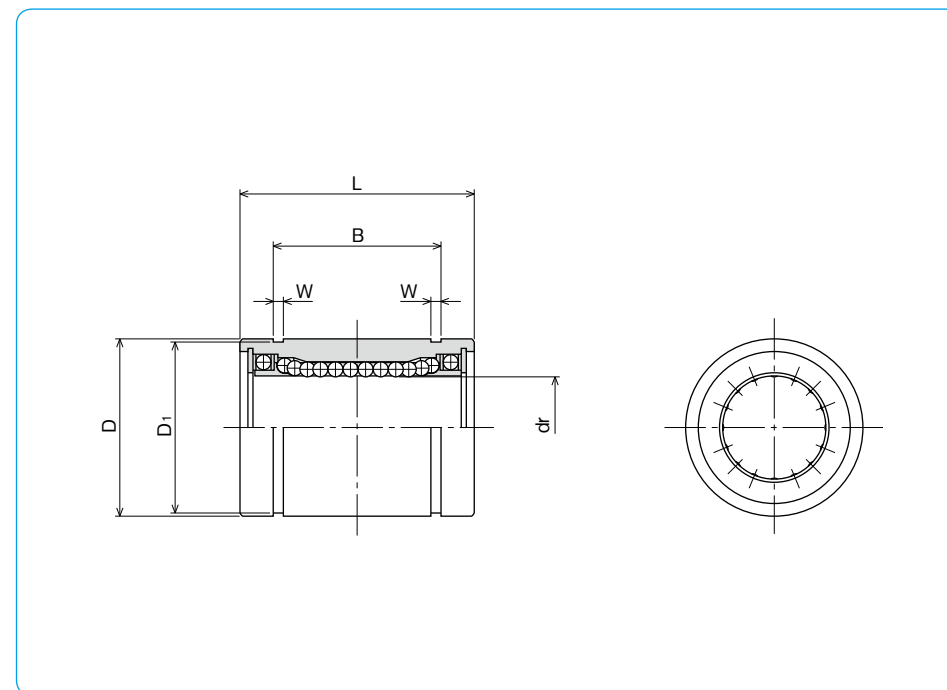

part number	dr		D		major dimensions			B	tolerance mm
	mm	tolerance μm	mm	tolerance μm	mm	tolerance mm	mm		
SRE 6	6		12	0	19		13.5		
SRE 8	8	+4	15	-11	24		17.5		
SRE10	10	-5	19		29		22		
SRE12	12		21	0	30	0	23		0
SRE13	13	+3	23	-13	32	-0.2	23		-0.2
SRE16	16	-6	28		37		26.5		
SRE20	20		32		42		30.5		
SRE25	25	+3	40	0	59	0	41		0
SRE30	30	-7	45	-16	64		44.5		
SRE40	40	+3/-8	60	0/-19	80	-0.3	60.5		-0.3

※If the inner contact diameter exceeds 40 mm, please contact NB.

W	D ₁	basic load rating		allowable revolutions per minute rpm	mass g	part number
		dynamic C N	static Co N			
1.1	11.5	78	176	300	10	SRE 6
1.1	14.3	137	314	300	20	SRE 8
1.3	18	157	372	300	39	SRE10
1.3	20	274	588	300	42	SRE12
1.3	22	323	686	300	56	SRE13
1.6	27	451	882	250	97	SRE16
1.6	30.5	647	1,180	250	133	SRE20
1.85	38	882	1,860	250	293	SRE25
1.85	43	1,180	2,650	200	371	SRE30
2.1	57	1,960	4,020	200	778	SRE40

1N≒0.102kgf

SREK TYPE

– Square Flange type –

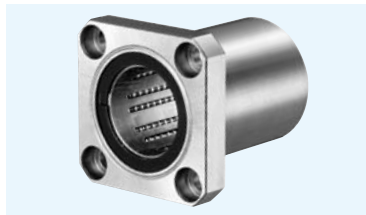

part number structure

example **SREK 25**

SREK type

inner contact diameter (dr)

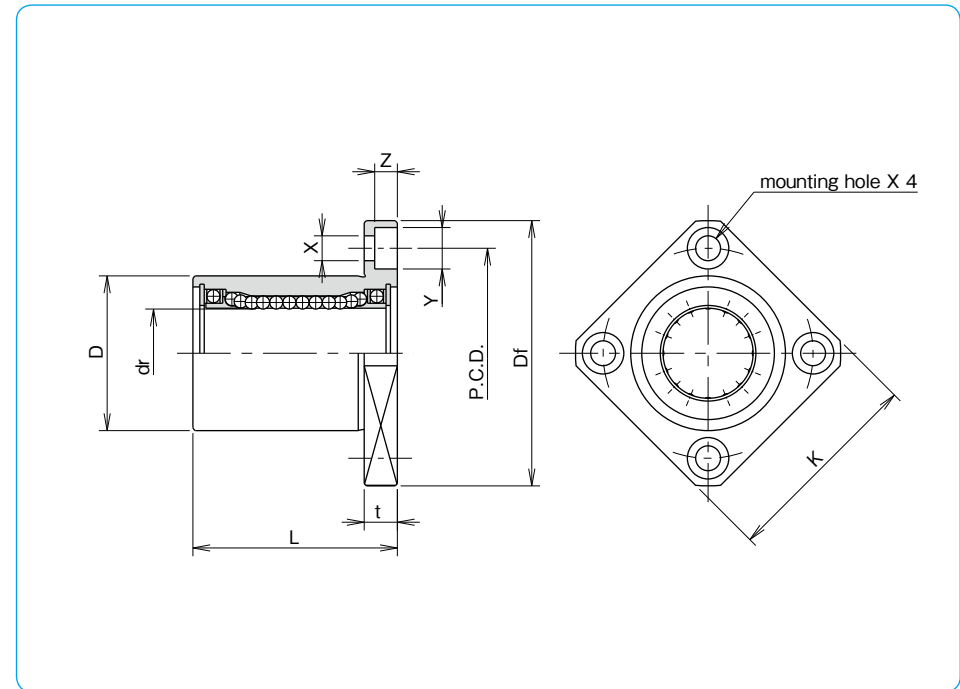

part number	dr		D		major dimensions			
	mm	tolerance μm	mm	tolerance μm	L ± 0.3 mm	Df mm	K mm	flange t mm
SREK 6	6		12	0	19	28	22	5
SREK 8	8	+4	15	-13	24	32	25	5
SREK10	10	-5	19		29	40	30	6
SREK12	12	+3	21	0	30	42	32	6
SREK13	13	-6	23	-16	32	43	34	6
SREK16	16		28		37	48	37	6
SREK20	20	+3	32	0	42	54	42	8
SREK25	25	-7	40	-19	59	62	50	8
SREK30	30		45		64	74	58	10

P.C.D. mm	X×Y×Z mm	perpendicularity μm	basic load rating		allowable revolutions per minute	mass g	part number
			dynamic C N	static Co N			
20	3.5×6×3.1	12	78	176	300	21	SREK 6
24	3.5×6×3.1		137	314	300	33	SREK 8
29	4.5×7.5×4.1		157	372	300	61	SREK10
32	4.5×7.5×4.1		274	588	300	67	SREK12
33	4.5×7.5×4.1		323	686	300	83	SREK13
38	4.5×7.5×4.1		451	882	250	126	SREK16
43	5.5×9×5.1	15	647	1,180	250	178	SREK20
51	5.5×9×5.1		882	1,860	250	355	SREK25
60	6.6×11×6.1		1,180	2,650	200	483	SREK30

1N≐0.102kgf

SMA-R TYPE

-Block type-



part number structure

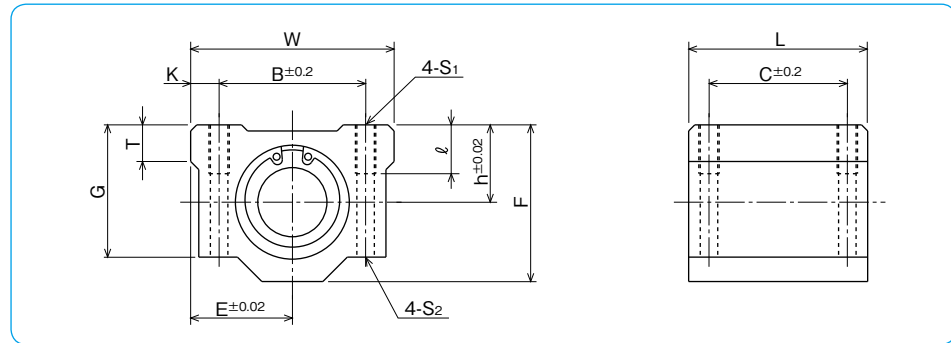
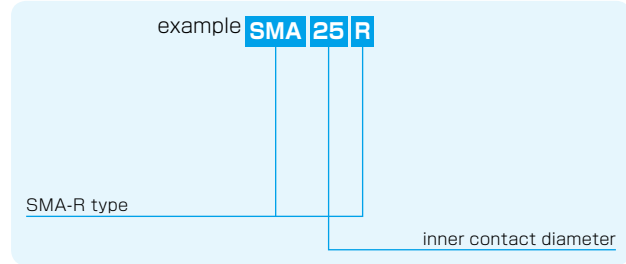

part number	inner contact diameter		major dimensions													basic load rating		allowable revolutions per minute	mass
	mm	tolerance μm	outer dimensions				mounting dimensions					dynamic	static	rpm	g				
			h	E	W	L	F	G	T	B	C	K	S ₁	ℓ	S ₂	C	Co		
SMA 6R	6		9	15	30	25	18	15	6	20	15	5	M4	8	3.4	78	176	300	33
SMA 8R	8	+4	11	17	34	30	22	18	6	24	18	5	M4	8	3.4	137	314	300	55
SMA 10R	10	-5	13	20	40	35	26	21	8	28	21	6	M5	12	4.3	157	372	300	93
SMA 12R	12		15	21	42	36	28	24	8	30.5	26	5.5	M5	12	4.3	274	588	300	104
SMA 13R	13	+3	15	22	44	39	30	24.5	8	33	26	5.5	M5	12	4.3	323	686	300	128
SMA 16R	16	-6	19	25	50	44	38.5	32.5	9	36	34	7	M5	12	4.3	451	882	250	216
SMA 20R	20		21	27	54	50	41	35	11	40	40	7	M6	12	5.2	647	1,180	250	286
SMA 25R	25	+3	26	38	76	67	51.5	42	12	54	50	11	M8	18	7	882	1,860	250	645
SMA 30R	30	-7	30	39	78	72	59.5	49	15	58	58	10	M8	18	7	1,180	2,650	200	824
SMA 40R	40	+3/-8	40	51	102	90	78	62	20	80	60	11	M10	25	8.7	1,960	4,020	200	1,719

1N=0.102kgf

SMA-RW TYPE

-Double-Wide Block type-



part number structure

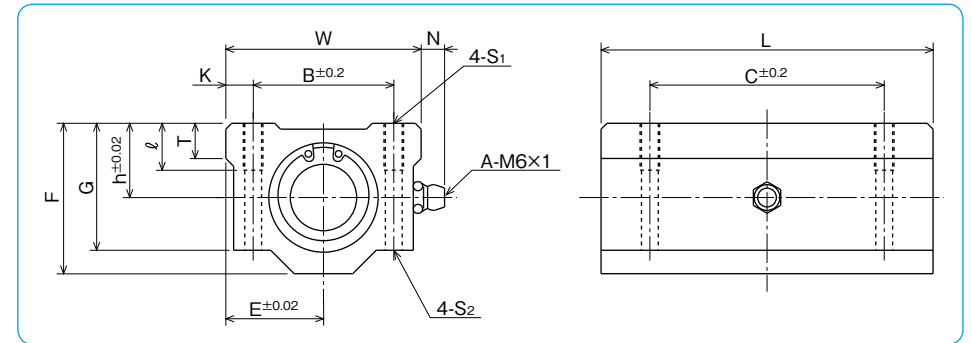
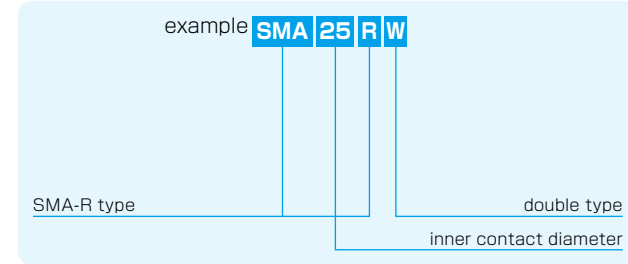

part number	inner contact diameter		major dimensions													basic load rating		allowable revolutions per minute	mass	
	mm	tolerance μm	outer dimensions				mounting dimensions					dynamic	static	rpm	g					
			h	E	W	L	F	G	T	N	B	C	K	S ₁	ℓ	S ₂	C	Co		
SMA 6RW	6		9	15	30	48	18	15	6	7	20	36	5	M4	8	3.4	126	352	300	68
SMA 8RW	8	+4	11	17	34	58	22	18	6	7	24	42	5	M4	8	3.4	222	628	300	113
SMA 10RW	10	-5	13	20	40	68	26	21	8	7	28	46	6	M5	12	4.3	254	744	300	188
SMA 12RW	12		15	21	42	70	28	24	8	6.5	30.5	50	5.75	M5	12	4.3	444	1,180	300	210
SMA 13RW	13	+3	15	22	44	75	30	24.5	8	6.5	33	50	5.5	M5	12	4.3	523	1,370	300	254
SMA 16RW	16	-6	19	25	50	85	38.5	32.5	9	6	36	60	7	M5	12	4.3	731	1,760	250	431
SMA 20RW	20		21	27	54	96	41	35	11	7	40	70	7	M6	12	5.2	1,050	2,360	250	568
SMA 25RW	25	+3	26	38	76	130	51.5	42	12	4	54	100	11	M8	18	7	1,430	3,720	250	1,282
SMA 30RW	30	-7	30	39	78	140	59.5	49	15	5	58	110	10	M8	18	7	1,910	5,300	200	1,638
SMA 40RW	40	+3/-8	40	51	102	175	78	62	20	5	80	140	11	M10	25	8.7	3,180	8,040	200	3,419

1N=0.102kgf

AK-R TYPE

-Compact Block type-



part number structure

example **AK 25 R**

AK-R type

inner contact diameter

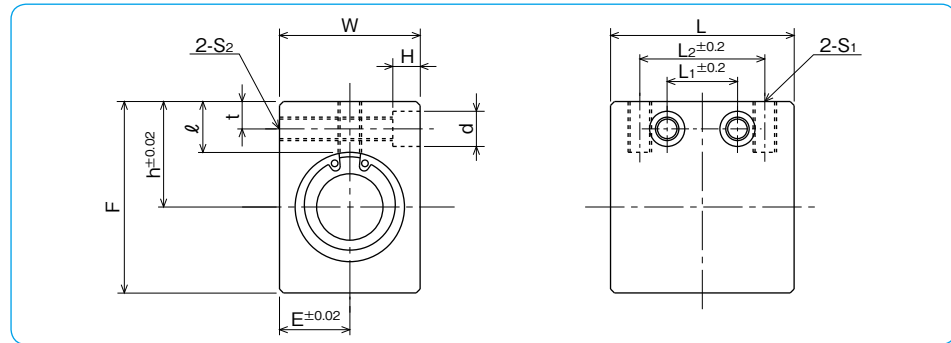

part number	inner contact diameter		major dimensions														basic load rating		allowable revolutions per minute	mass g
			outer dimensions					mounting dimensions									dynamic	static		
			h	E	W	L	F	L ₂	S ₁	ℓ	L ₁	t	S ₂	d	H	C	Co			
AK 6R	6		14	8	16	27	22	18	M4	8	9	5	M4	6	5	78	176	300	27	
AK 8R	8	+4	16	10	20	32	26	20	M5	8.5	10	5	M4	6	5	137	314	300	48	
AK10R	10	-5	19	13	26	39	32	27	M6	9.5	15	6	M5	8	6	157	372	300	94	
AK12R	12		20	14	28	40	34	27	M6	9.5	15	6	M5	8	6	274	588	300	105	
AK13R	13	+3	25	15	30	42	43	28	M6	13.5	16	7	M6	9	7	323	686	300	151	
AK16R	16	-6	27	18	36	47	49	32	M6	13	18	7	M6	9	7	451	882	250	238	
AK20R	20		31	21	42	52	54	36	M8	15	18	8	M8	11	8	647	1,180	250	328	
AK25R	25	+3	37	26	52	69	65	42	M10	17	22	9	M10	14	10	882	1,860	250	669	
AK30R	30	-7	40	29	58	74	71	44	M10	17.5	22	9	M10	14	10	1,180	2,650	200	856	

1N≒0.102kgf

AK-RW TYPE

-Double-Wide Compact Block type-



part number structure

example **AK 25 R W**

AK-R type

double type

inner contact diameter

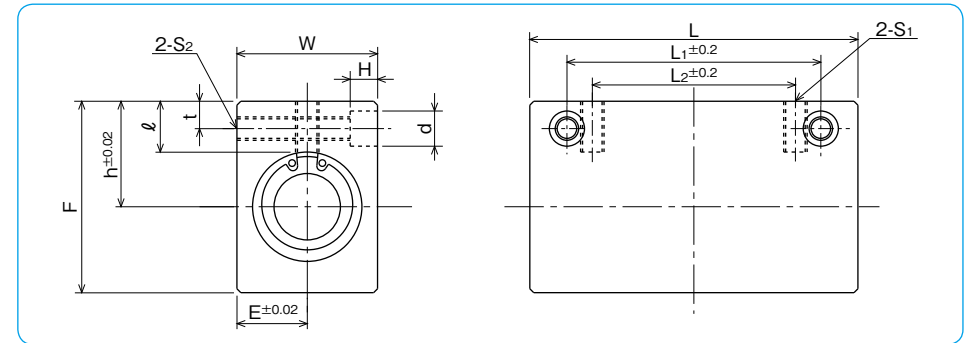

part number	inner contact diameter		major dimensions														basic load rating		allowable revolutions per minute	mass g
			outer dimensions					mounting dimensions									dynamic	static		
			h	E	W	L	F	L ₂	S ₁	ℓ	L ₁	t	S ₂	d	H	C	Co			
AK 6RW	6		14	8	16	46	22	20	M4	8	30	5	M4	6	5	126	352	300	48	
AK 8RW	8	+4	16	10	20	56	26	30	M5	8.5	42	5	M4	6	5	222	628	300	89	
AK10RW	10	-5	19	13	26	68	32	36	M6	9.5	50	6	M5	8	6	254	744	300	175	
AK12RW	12		20	14	28	70	34	36	M6	9.5	50	6	M5	8	6	444	1,180	300	196	
AK13RW	13	+3	25	15	30	74	43	42	M6	13.5	55	7	M6	9	7	523	1,370	300	281	
AK16RW	16	-6	27	18	36	84	49	52	M6	13	65	7	M6	9	7	731	1,760	250	450	
AK20RW	20		31	21	42	94	54	58	M8	15	70	8	M8	11	8	1,050	2,360	250	626	
AK25RW	25	+3	37	26	52	128	65	80	M10	17	100	9	M10	14	10	1,430	3,720	250	1,299	
AK30RW	30	-7	40	29	58	138	71	90	M10	17.5	110	9	M10	14	10	1,910	5,300	200	1,662	

1N≒0.102kgf

SMP-R TYPE

—Pillow Block type—



part number structure

example **SMP 25 R**

SMP-R type

inner contact diameter

part number	inner contact diameter		major dimensions						
	mm	tolerance μm	outer dimensions						
			h mm	E mm	W mm	L mm	F mm	G mm	M mm
SMP13R	13	+3	25	25	50	32	46	8	36
SMP16R	16	-6	29	27.5	55	37	53	10	40
SMP20R	20	+3 -7	34	32.5	65	42	62	12	48
SMP25R	25		40	38	76	59	73	12	59
SMP30R	30	+3/-8	45	42.5	85	64	84	15	69
SMP40R	40		60	62	124	80	112	18	86

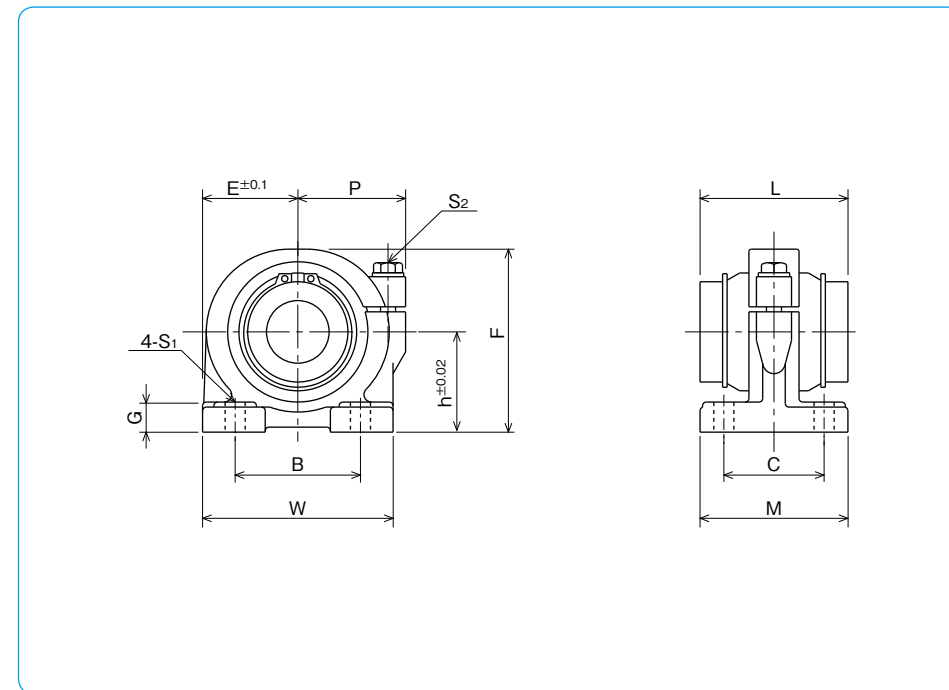

P mm	mounting dimensions			adjustment screw size S2	basic load rating		allowable revolutions per minute rpm	mass g	part number
	B mm	C mm	S ₁ mm		dynamic C N	static C ₀ N			
30	30	26	7 (M5)	M5	323	686	300	266	SMP13R
32	35	29	7 (M5)	M5	451	882	250	369	SMP16R
37	40	35	8 (M6)	M6	647	1,180	250	690	SMP20R
43	50	40	8 (M6)	M6	882	1,860	250	970	SMP25R
49	58	46	10 (M8)	M8	1,180	2,650	200	1,420	SMP30R
68	76	64	12 (M10)	M10	1,960	4,020	200	3,585	SMP40R

1N≐0.102kgf

SLIDE ROTARY BUSH RK TYPE

NB's RK type slide rotary bush is a highly accurate and high load capacity bearing providing smooth continuous linear and rotational motions. Its structure imposes no constraints on linear and rotational motions. It is much more compact than a standard slide bush with separate rotational bearing.

STRUCTURE AND ADVANTAGES

The RK type slide rotary bush uses a retainer similar to that used in the SR type stroke bush. This retainer gives a smooth motion in a high rotational application. SM type slide bush is incorporated, providing the stable and smooth linear motion. Relatively large ball elements are used for high load capacity.

1. A smooth unlimited linear and rotational motion is obtained.
2. There is no need to machine separate housing.
3. High accuracy is ensured for extended period of usage.
4. Its high compatibility eliminates replacement problems.
5. High rigidity enables it to withstand an unbalanced load and large load.

※For best performance, please select tolerance of h5 for the shaft.

Calculation of Life:

$$L = \left(\frac{f_H \cdot f_T \cdot f_C \cdot C}{f_W \cdot P} \right)^3 \times 50$$

L: rated life (km) f_H: hardness coefficient
 f_T: temperature coefficient f_C: contact coefficient
 f_W: applied load coefficient
 C: basic dynamic load rating (N) P: applied load (N)
 ※Refer to page Eng-5 for the coefficients.

Figure E-6 Structure of RK Slide Rotary Bush

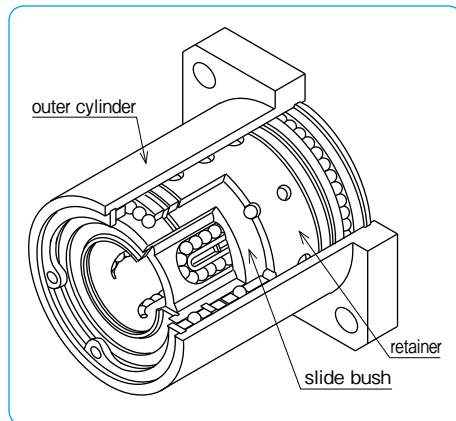

RK TYPE



part number structure

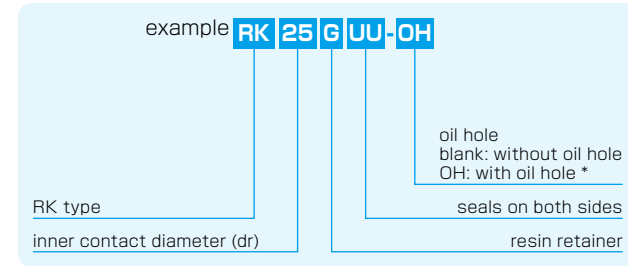

*Oil hole is for rotary-portion lubrication.

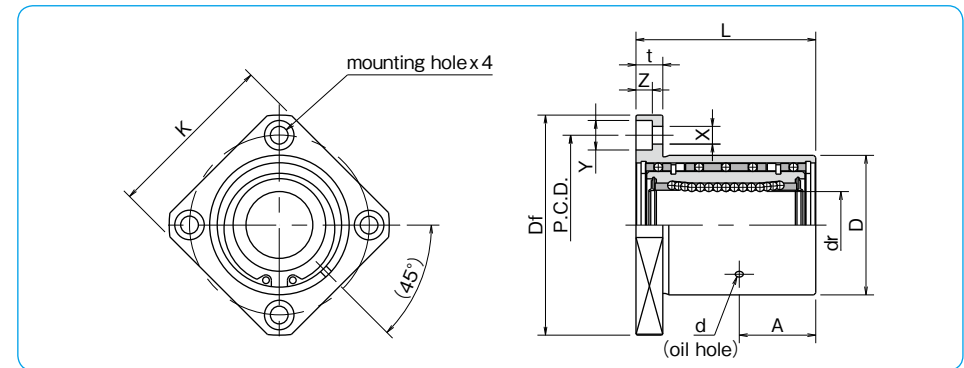

part number	dr		D		L	major dimensions				flange		basic load rating		allowable revolutions per minute	mass		
	mm	tolerance	mm	tolerance		mm	A	d	Df	K	t	P.C.D.	X×Y×Z			C	Co
RK12GUU	12	0	32	0	36	15	2	54	42	8	43	5.5×9×5.1	510	784	500	180	
RK16GUU	16	-9	40	-25	45	19.5	2	62	50	8	51	5.5×9×5.1	774	1,180	500	280	
RK20GUU	20	0	45	0	50	±0.3	21.5	3	74	58	10	60	6.6×11×6.1	882	1,370	400	420
RK25GUU	25	-10	52	0	67	28.5	3	82	64	10	67	6.6×11×6.1	980	1,570	400	680	
RK30GUU	30	-10	60	-30	74	31	3	96	75	13	78	9×14×8.1	1,570	2,740	400	990	

1N≒0.102kgf