

SLIDE GUIDE Miniature SER Type

The NB slide guide SER type is a linear motion bearing utilizing the rotational motion of precision rollers placed in two rows. Despite its compactness, it can be used in various applications requiring high load capacity.

STRUCTURE AND ADVANTAGES

The SER type slide guide consists of a rail with two precision-machined raceway grooves and a block assembly. The block assembly consists of the main body, rollers, and bottom retainers. All of these components are made of metallic materials.

High Load Capacity and Long Life

Since roller elements are used, the contact surface is large which provides a high load capacity and a long travel life.

Compactness

Since a cross roller method is utilized, only two raceway grooves are necessary and presents a very compact package.

Moment Resistant Type

The wide block design (WA type) has an extremely high moment loading capacity. This will allow for single guide designs in the most demanding and compact applications.

Tapped Hole Rail Type

For the SER rails, counterbore (standard) and optional tapped hole (N) types are available enabling various installation methods.

All Stainless Steel Type

The SERS type slide guide is made of all stainless steel components, making it ideal for high temperature, clean room or vacuum applications.

Figure A-44 Structure of SER type Slide Guide

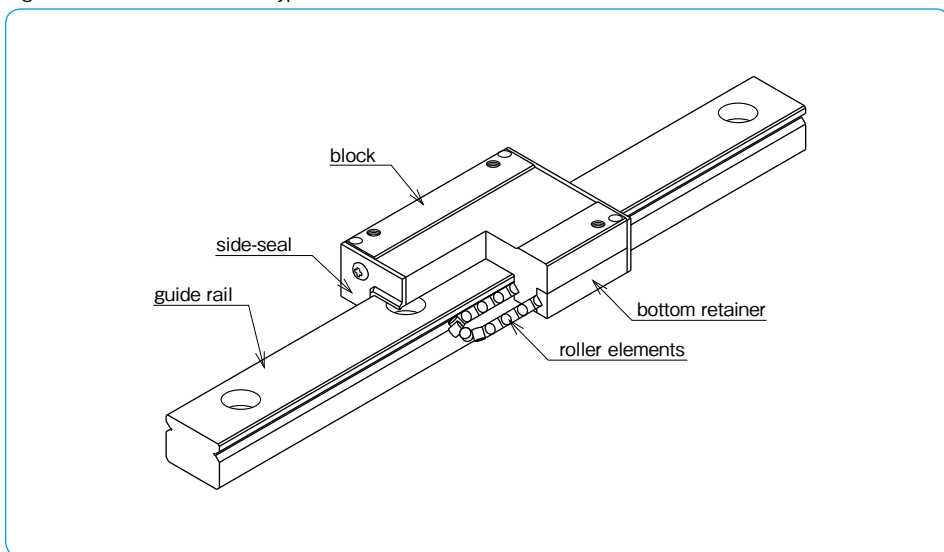

TYPES

The SER type slide guides are available with a standard block or a wide block (WA) configuration. Each type can be selected with standard rails of counterbore holes or the optional N-Type rails of tapped holes. For anti-corrosion, all stainless steel type is also available with all stainless steel components.

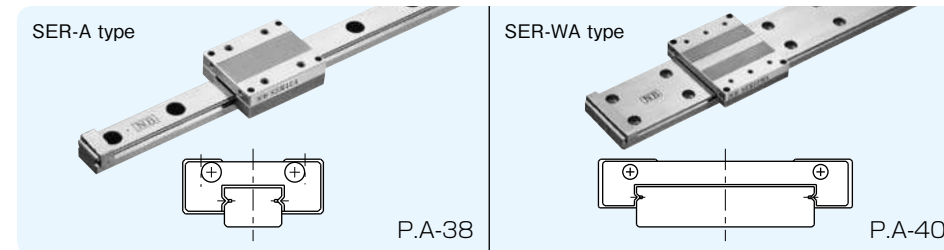

ACCURACY

The SER-type slide guides are available with high grade accuracy (blank) or precision grade accuracy (P).

Table A-16 Accuracy unit / mm

accuracy grade	high	precision
accuracy symbol	blank	P
allowable dimensional difference in height H	±0.015	±0.008
paired difference for height H	0.015	0.007
allowable dimensional difference in width W	±0.020	±0.010
paired difference for width W	0.020	0.010
Running parallelism of surface C to surface A	refer to Figure A-45,46	
Running parallelism of surface D to surface B		

Figure A-45 Accuracy

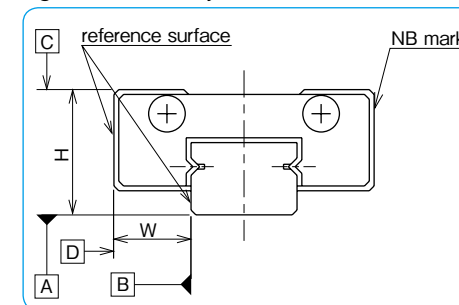
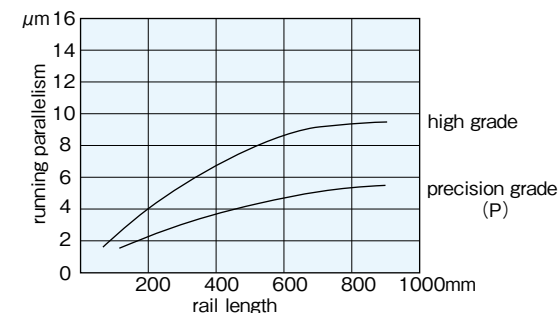

Figure A-46 Motion Accuracy



PRELOAD

The SER(S) type slide guides are available only with a standard (0 to slightly negative clearance) preload.

RAIL LENGTH

Slide guides with most commonly used lengths are available as standard. For slide guides with a non-standard length, unless otherwise specified, the distance from one end of the rail to the first hole center (N) will be within the ranges listed in Tables A-17 and A-18, satisfying the following equation.

$$L = M \cdot P + 2N$$

L: length (mm)
N: distance from the end of the rail to the first hole center (mm)
P: hole pitch (mm) M: number of pitches

Table A-17 N Dimension (standard type) unit/mm

part number		N		L max.
standard	anti-corrosion	and over	less than	
SER 9A	SERS 9A	4	14	275
SER12A	SERS12A		16.5	470
SER15A	SERS15A		24	670
SER20A	SERS20A	6	36	880

Figure A-47 Rail

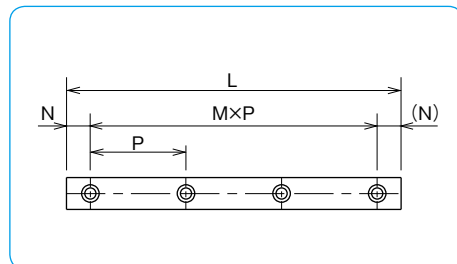

Table A-18 N Dimension (wide type) unit/mm

part number		N		L max.
standard	anti-corrosion	and over	less than	
SER 9WA	SERS 9WA	4	19	290
SER12WA	SERS12WA	5	25	470
SER15WA	SERS15WA			670

MOUNTING

Mounting Surface Profile

Slide guides are mounted by pushing the reference surface of the rail and the block against the shoulder provided on the mounting surface. An escape groove or a radius corner should be provided at the corner of the shoulder, as shown in Figs.A-48 and A-49, to prevent interference. The recommended shoulder height and corner radius are shown in Table A-19 and Table A-20 respectively.

Figure A-48 Mounting Reference Surface Profile-1

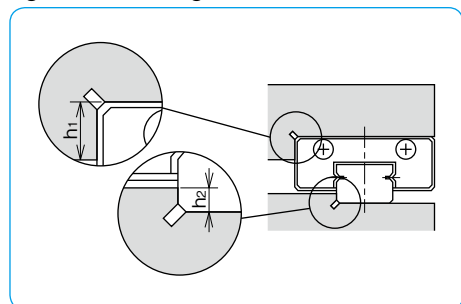

Table A-19 Shoulder Height Dimensions unit/mm

part number	shoulder height on the block side		shoulder height on the rail side
	h1	h2	
SER 9A	3	1.5	5
SER12A	4	2	
SER15A	5	3.5	
SER20A	5	5	2.5
SER 9WA	3		
SER12WA	4		
SER15WA	5		

Figure A-49 Mounting Reference Surface Profile-2

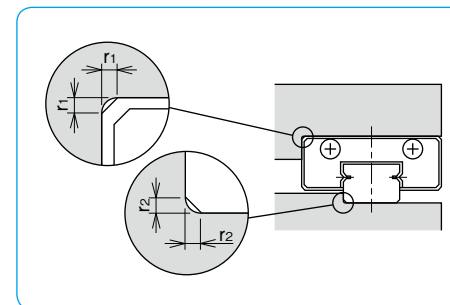

Table A-20 Maximum Corner Radius Values unit/mm

part number	block mounting part	rail mounting part
	r1	r2
SER 9A	0.3	0.1
SER12A		0.3
SER15A		
SER20A		0.5
SER 9WA		0.3
SER12WA		
SER15WA		

Recommended Torque Values

The screws to fasten the rail should be tightened to an equal torque using a torque wrench in order to secure the motion accuracy. The recommended torque values are given in Table A-21. Please adjust the torque depending on the operating conditions.

Table A-21 Recommended Torque unit/N·m

size	M2	M3	M4	M5	M6
recommended torque	0.3	1.0	2.3	4.7	8.0

(for stainless steel screw A2-70)

MOUNTING SCREW

Small screws for the SER(S) type slide guide are available from NB.

Table A-22 unit/mm

size	pitch	length l	application
M2	0.4	4,5,6,8,10	SER 9A

(stainless steel)

Figure A-50 Mounting Screw

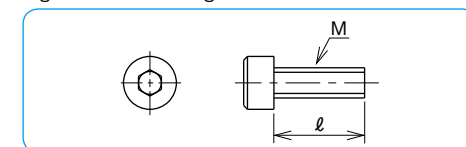

LUBRICATION

A high grade lithium soap based grease is applied to the NB slide guides prior to shipment for immediate use. Please relubricate with a similar type of grease periodically depending on the operating conditions. For use in clean rooms or vacuum environments, NB slide guides without grease are available upon request. Please contact NB for customer specified grease types.

A special syringe lubricant dispenser is available from NB as an option.

Please refer to page Eng-39 for details on the low dust generation grease.



SER-A TYPE

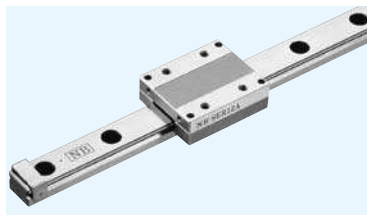

part number structure

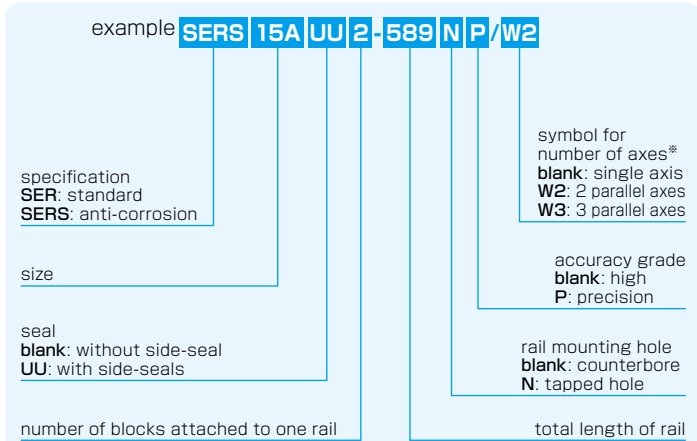

* The symbol for the number of axes does not mean the number of rails ordered.

part number		assembly dimensions		block dimensions							
standard	anti-corrosion	H	W	B	L ₁	L ₂	P ₁	P ₂	S ₁	ℓ	b
		mm	mm	mm	mm	mm	mm	mm		mm	mm
SER 9A	SERS 9A	10	5.7	20	28	32	15	13	M2	2.5	7.8
SER12A	SERS12A	13	8	27	32	36	20	15	M3	3	10.5
SER15A	SERS15A	16	8.5	32	40	44	25	20		4	11.5
SER20A	SERS20A	25	13	46	60	66	38	38	M4	6	17.5

part number		standard rail length							maximum length
standard	anti-corrosion	L							mm
		mm							
SER 9A	SERS 9A	55	75	95	115	155	195	275	275
SER12A	SERS12A	120	170	220	270	320	370	470	470
SER15A	SERS15A	150	230	310	430	550	670		670
SER20A	SERS20A	220	280	340	460	640	880		880

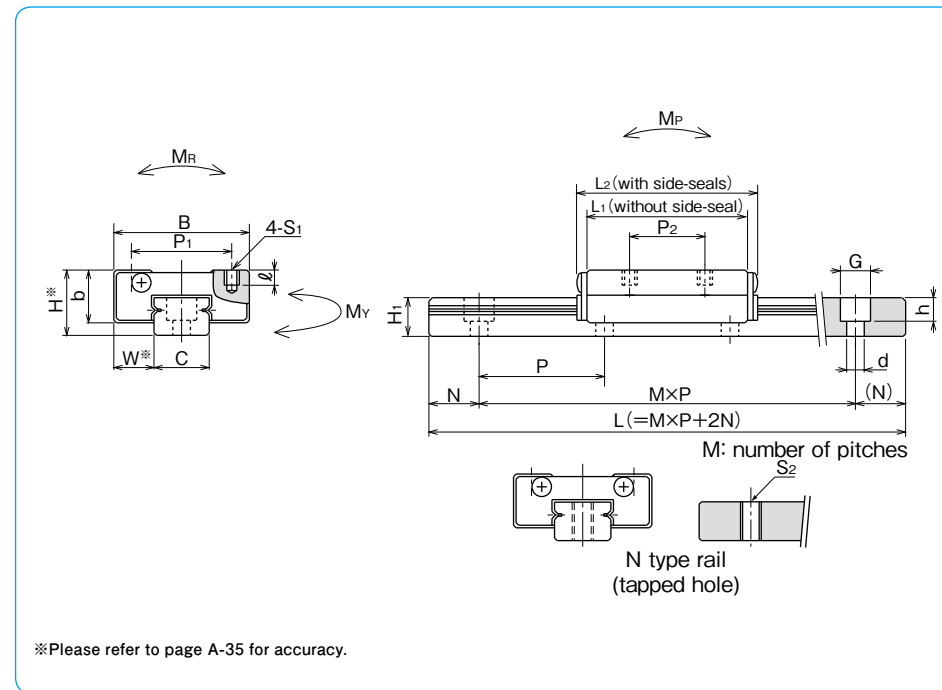

guide rail dimensions		basic load rating		allowable static moment			mass		block size				
H ₁	C	S ₂	d×G×h	N	P	C _d	C _o	M _P	M _Y	M _R	block	guide rail	block size
mm	mm		mm	mm	mm	kN	kN	N·m	N·m	N·m	g	g/100mm	
5.5	8.6	M4	2.6×4.5×3	7.5	20	2.65	2.94	11.8	13.7	19.6	25	35	9A
7.5	11			10	25	3.43	3.92	15.7	17.6	29.4	51	55	12A
9.5	15	M5	3.5×6×4.5	15	40	4.70	5.78	29.0	32.3	54.9	82	100	15A
15	20	M6		6×9.5×8.5	20	60	8.82	9.80	59.0	66.6	151	280	230

1kN≒102kgf 1N·m≒0.102kgf·m

SER-WA TYPE

– Wide Type –



part number structure

example **SERS 15WA UU 2-589 N P/W2**

specification SER : standard SERS : anti-corrosion	size	seal blank : without side-seal UU : with side-seals	number of blocks attached to one rail	symbol for number of axes* blank : single axis W2 : 2 parallel axes W3 : 3 parallel axes	accuracy grade blank : high P : precision	rail mounting hole blank : counterbore N : tapped hole	total length of rail
--	------	---	---------------------------------------	--	---	--	----------------------

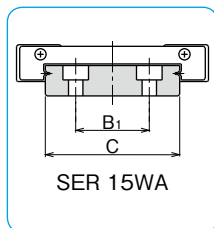

* The symbol for the number of axes does not mean the number of rails ordered.

part number		assembly dimensions		block dimensions							
standard	anti-corrosion	H	W	B	L ₁	L ₂	P ₁	P ₂	S ₁	ℓ	b
mm	mm	mm	mm	mm	mm	mm	mm	mm	mm	mm	mm
SER 9WA	SERS 9WA	12	6.5	30	35	39	21	10	M3	3	8.8
SER12WA	SERS12WA	14	9	40	40	44	28	12.5			11
SER15WA	SERS15WA	16		60	50	54	45	15	M4	4.5	11.5

part number		standard rail length L							maximum length
standard	anti-corrosion	mm							mm
SER 9WA	SERS 9WA	80	110	140	170	200	260	290	290
SER12WA	SERS12WA	110	150	190	230	310	390	470	470
SER15WA	SERS15WA	150	230	310	430	550	670		670

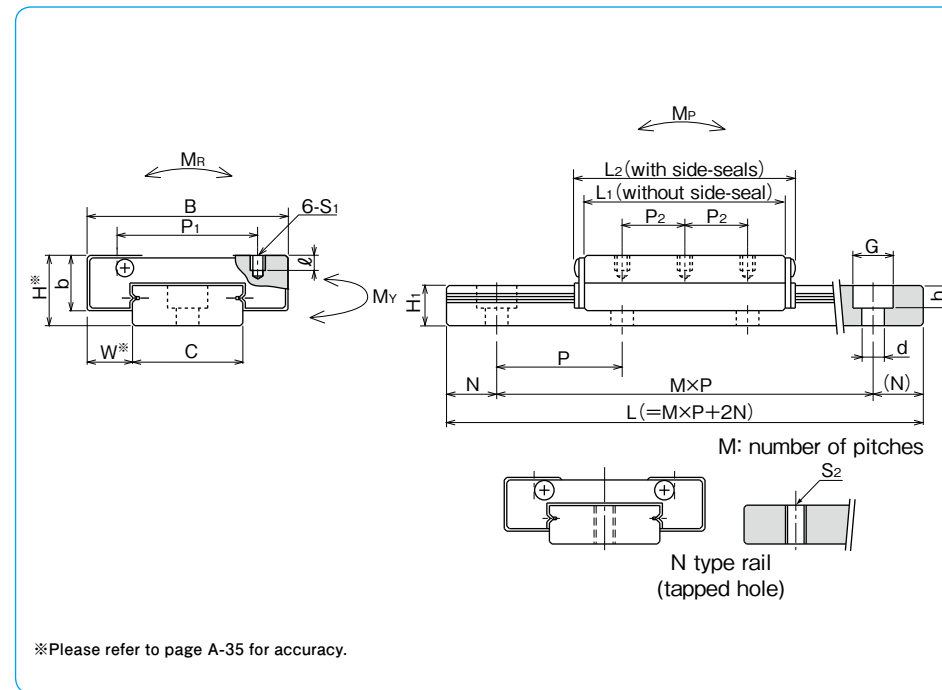

guide rail dimensions		basic load rating		allowable static moment			mass		block size		
H ₁	C	B ₁	S ₂	dynamic	static	M _P	M _Y	M _R	block	guide rail	block size
mm	mm	mm	mm	C	Co	N · m	N · m	N · m	g	g/100mm	
7.5	17	—	M4	3.43	3.72	24.5	27.4	51.9	46	90	9WA
8	22	—	M5	4.41	5.00	35.3	39.2	85.3	92	122	12WA
9.5	42	23		7.35	8.92	55.9	61.7	215.0	165	280	15WA

1kN ≒ 102kgf 1N · m ≒ 0.102kgf · m