

# MT 3100<sub>up</sub> MT 3200<sub>up</sub>

EASY - ALU

**NEW**



PLUS version



automotive service equipment

# MT 3100up MT 3200up

## EASY - ALU

### EQUILIBRATRICI ELETTRONICHE A DISPLAY PER AUTOVETTURE, TRASPORTO LEGGERO E MOTOVEICOLI

ELECTRONIC BALANCING WITH DISPLAY FOR CARS, LIGHTWEIGHT TRANSPORT VEHICLES AND MOTOR VEHICLES

Equilibratrici digitali ad elevate prestazioni e software di nuovissima concezione.

#### Versioni disponibili:

**MT3200 up PLUS:** versione con introduzione automatica di diametro e distanza ruota. Freno di stazionamento elettrico.

**MT3200 up:** versione con introduzione automatica di diametro e distanza ruota.

**MT3100 up:** versione con introduzione manuale di diametro e distanza ruota.

Tutte le versioni sono normalmente fornite con protezione ruota e lancio automatico.

#### Available versions:

High performance digital wheel balancer with latest generation software solutions

**MT3200 up PLUS:** version with automatic input of wheel diameter and distance. Electrical clamping brake.

**MT3200 up:** version with automatic input of wheel diameter and distance.

**MT3100 up:** version with manual input of wheel diameter and distance.

All models are normally supplied with automatic spin by pushing down wheel guard.

Low rotation speed and double spinning button allow the machine to be used without wheel guard even in EEC area.

## TUTTI I MODELLI ALL MODELS

### 1. DISPLAY E PIANALE PORTA PESI / DISPLAY AND WEIGHT HOLDER TRAY

**Visualizzatore a doppio display,** permette una selezione rapida ed intuitiva dei programmi di equilibratura e l'accesso immediato alle funzioni di lavoro più comuni.

Pianale portapesi ergonomico e spazioso per contrappesi ed accessori da lavoro realizzato con materiale ad elevata resistenza.

**A double display control panel** enables a quick and intuitive selection of the balancing mode and immediate access to the most common operating functions.

Ergonomic and spacious tray in highly resilient material for counterweights and work accessories.



### 2. GRUPPO DI LANCIO / SPIN UNIT

Gruppo di lancio derivato dai modelli superiori, fornisce caratteristiche di precisione e funzionalità tipiche di equilibratrici di fascia alta: tempo di ciclo ridotto, misura su ruote con peso fino a 75 kg ed equilibratura di ruote con offset interno fino a 275 mm senza l'utilizzo di distanziali aggiuntivi. L'innovativa motorizzazione a manutenzione zero ne assicura la massima affidabilità.

Spin unit derives from the superior models of the B-Series and provides functional features typical of the upper models: reduced cycle time, measuring wheels weighing up to 75 kg and wheel balancing with inside offset of up to 275 mm without using additional spacer. The innovative drive and zero maintenance ensure maximum reliability.

### 3. BASE CON PIEDE (optional) / SUPPORT BASE (optional)

Piede per equilibrare ruote fino a 50 kg di peso senza dover fissare la macchina al suolo.

Front support base for balancing wheels up to 50 kg without fastening the machine to the ground.

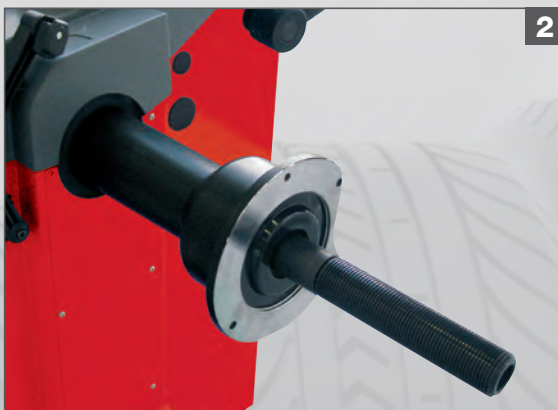

**NEW**



#### 4. ACQUISIZIONE DATI RUOTA / WHEEL DIMENSION DETECTION

**Acquisizione elettronica di diametro e distanza** con funzione AUTOSELECT che attiva automaticamente i programmi di equilibratura evitando le selezioni da tastiera (non nella versione 3100 up).

**Electronic input of wheel diameter and distance** with AUTOSELECT function which automatically activates the balancing programmes, avoiding keypad selection (no in the 3100 up version).

**NEW**



#### 5. PESI ADESIVI / ADHESIVE WEIGHTS

**Tre sistemi per il posizionamento dei pesi adesivi:** con clip portapesi (\*), con indicatore laser a ore 6 (\*) o manualmente a ore 12.

**Three modes to position the adhesive weights:** with the weight holder clip (\*), with the 6 o'clock laser indicator (\*) or manually at 12 o'clock.



\*Funzione o accessorio a richiesta. Vedi tabella / *Optional function or accessory. See diagram*



NEW



## 6. TL3

**Rilevatore sonar TL3** per la misura automatica della larghezza ruota senza contatto (\*).

**TL3 automatic sensor** for measurement of wheel width (\*).



NEW



## 7. POSIZIONAMENTO AUTOMATICO / AUTO POSITIONING

**Posizionamento automatico (RPA)** della ruota nel punto di applicazione del peso di equilibratura e freno di stazionamento elettrico (\*).

**Automatic wheel positioning (RPA)** in the point where the balancing weight has to be applied and electrical positioning brake (\*).

NEW



## 8. ILLUMINATORE LED E LASER LPS / LED SPOTLIGHT AND LPS LASER

L'**illuminatore led** illumina l'area di lavoro per facilitare le operazioni di pulizia del cerchione e l'applicazione dei contrappesi. I contrappesi possono essere posizionati con estrema velocità utilizzando il **puntatore laser** a ore 6 (\*).



**LED spotlight** to light-up the work area and make it easier to clean the rim, check the wheel and apply weights. The adhesive weights can be positioned extremely rapidly using the **laser pointer** at 6 o'clock (\*).



\*Funzione o accessorio a richiesta. Vedi tabella / *Optional function or accessory. See diagram*

# MT 3100up MT 3200up

EASY - ALU



## 9. FRENO DI BLOCCAGGIO (A RICHIESTA) PEDAL WHEEL HOLDER (OPTIONAL)

Freno di bloccaggio albero porta ruota a pedale, facilita le operazioni di bloccaggio e sbloccaggio ruota e l'applicazione dei contrappesi (\*).

*Pedal wheel holder shaft locking brake, makes easier both the wheel clamping and unclamping options as well as the application of weights (\*).*



# MT 3100up MT 3200up MT 3200up PLUS

Programmi speciali per tutti i modelli Special Programmes for all models



## HIDDEN WEIGHT

Programma per nascondere il peso dietro le razze per un migliore impatto estetico del cerchio.  
*Programme for concealing counterweights behind spokes for improved wheel aesthetics.*



## OPT FLASH

Programma che indica la posizione di montaggio ideale tra cerchio e pneumatico al fine di ridurre lo squilibrio complessivo della ruota.

*Programme indicating ideal wheel/tyre assembly position to reduce overall wheel imbalance.*



## EASY WIDTH

Calcolo automatico della larghezza ruota anche in assenza del sensore esterno TL3  
L'equilibratrice fa una previsione della larghezza ruota riducendo i tempi operativi (\*).

*Automatic calculation of the width even if the TL3 external sensor is not present.  
The wheel balancer calculates the width by reducing the operational time (\*).*

Programmi di utilità generale: calibrazione, servizio, diagnostica / General utility programs: calibration, servicing, self-diagnostic

\*Funzione o accessorio a richiesta. Vedi tabella / Optional function or accessory. See diagram

# MONDOLFO FERRO

**MODELLO**  
**MODEL**



MT 3100up				✓					✓
MT 3200up			✓	✓	✓	✓		✓	✓
MT 3200up PLUS	✓	✓	✓	✓	✓		✓	✓	



**STANDARD**



**OPTIONAL**

## Dati tecnici Technical data

MT 3100up									
MT 3200up	75 Kg	10" - 28"	1,5" - 20"	600 mm	1117 mm	75 Kg	115/230V	90-130 rpm	100 W
MT 3200up PLUS		1" - 35"					1Ph - 50/60Hz		

## Dimensioni Dimensions

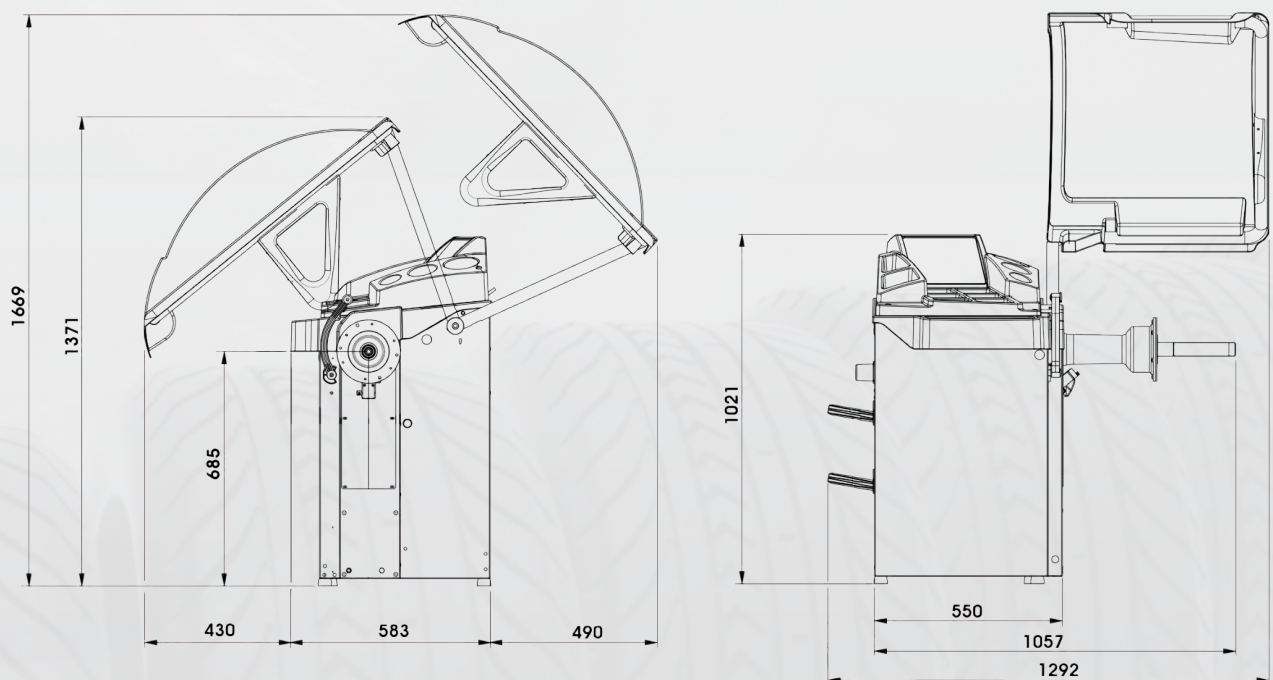

Dotazione Equipment

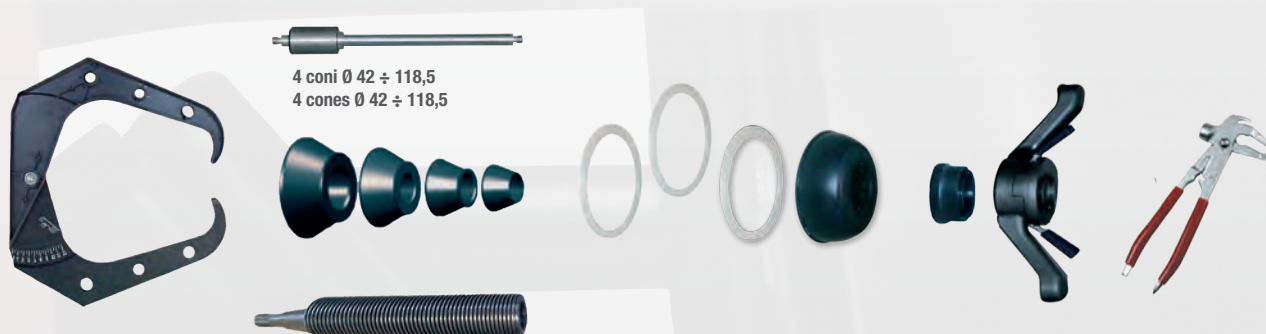

Accessori raccomandati Recommended accessories

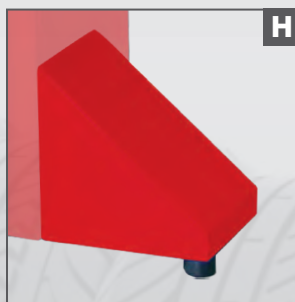
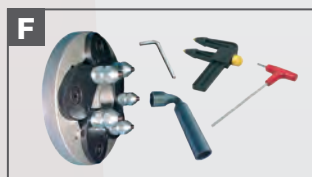
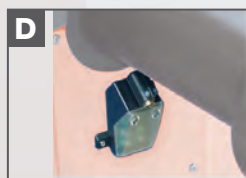
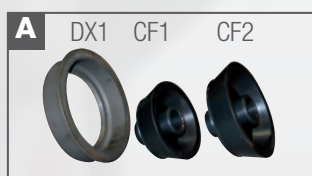

**A. DX\CBF-> 8-21100141**

Accessorio di centraggio per furgoni e fuoristrada con foro centrale Ø 117÷173 mm

*Centring accessory for van and off-road wheels with central hole with Ø 117÷173 mm*

**B. CB-> 8-21100191**

Freno a pedale

*Pedal brake*

**C. CLIP-> 8-21100159**

Terminale portapesi STD ALU

*STD ALU weight-holder terminal*

**D. -> 8-21100238**

Illuminatore interno ruota a LED e puntatore LASER

*STD ALU weight-holder terminal*

**E. TL3-> 8-21100232**

Rilevatore larghezza ruota

*Automatic sensor wheel width*

**F. FRU-> 8-21100091**

Flangia universale per ruote vettura senza foro centrale

*Universal flange for wheels without central hole*

**G. WLO -> 8-21100230**

Sollevatore effetto "senza peso"

*"Weightless effect" wheel lifter*

**H. PL50-> 8-21100158**

Piede per ruote fino a 50 kg

*Base for wheels up to 50 kg*

Per maggiori informazioni consultare il catalogo accessori /  
For more information, please consult the accessories catalogue

