



## 4001

Wheel Dumpers



### The four-wheel pro – 4001.

Shifts up to 4,000 kg payload quickly and efficiently and then dumps the load with the spot on precision of the standard swivel-tipping skip. Guaranteed to get things going on the building site.

- Low maintenance hydrostatic four-wheel drive;
- swivel tipping skip (standard), large-volume, robust and hard-wearing skip design; standard skip capacity of up to 2,550 l (heaped).
- With high ground clearance and a top speed of 21 km/h transport jobs get done fast.
- Maximum payload 4,000 kg
- More of a speedster: the 4001s Speed Version gets up to 25 km/h!

### Technical specifications

#### Operating data

Payload	4,000 kg
---------	----------



Net weight	2,730 kg
Skip capacity level	1,650 l
Skip capacity heaped	2,230 l
Engine / Motor	
Engine / Motor manufacturer	Yanmar
Engine / Motor type	4TNV88
Engine / Motor	Diesel
Engine performance acc. to ISO 3046/1	34.1 kW
Displacement	2,189 cm <sup>3</sup>
Travel speed	21 km/h
Articulation angle	37 °
Pendulum angle	15 °
Turning radius	3,730 mm
Gradeability	50 %
L x W x H	4,200 x 1,795 x 2,700 mm



## Dimensions

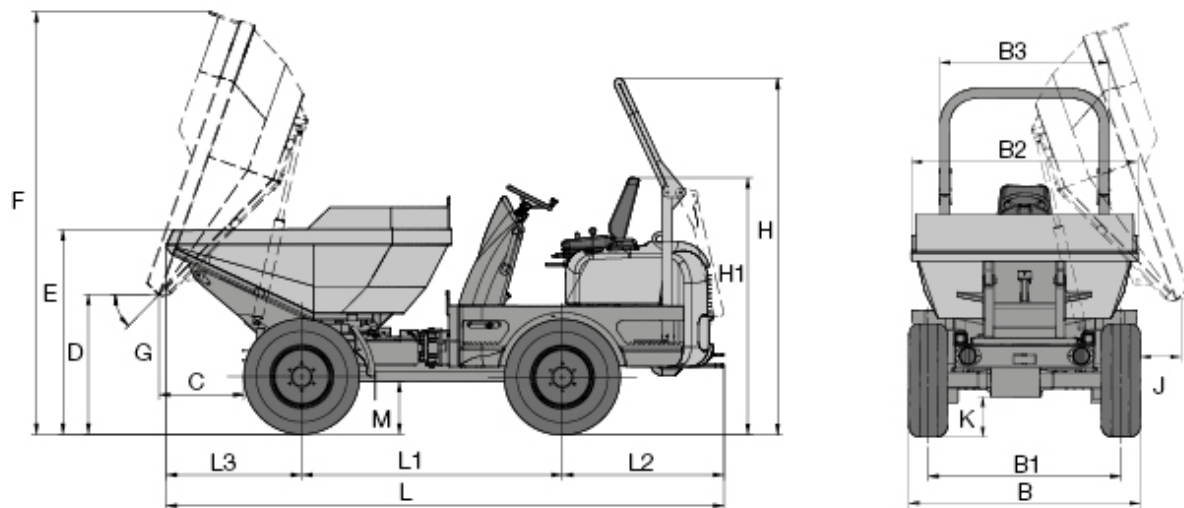

### Please note

that product availability can vary from country to country. It is possible that information / products may not be available in your country. More detailed information on engine power can be found in the operator's manual; the stated power may vary due to specific operating conditions.

Subject to alterations and errors excepted. Applicable also to illustrations.

Copyright © 2016 Wacker Neuson SE.