

MICROREP

DMS 680 - Gage Calibration

Universal length measuring system
gauge inspection for quality requirements



JOINT
INSTRUMENTS

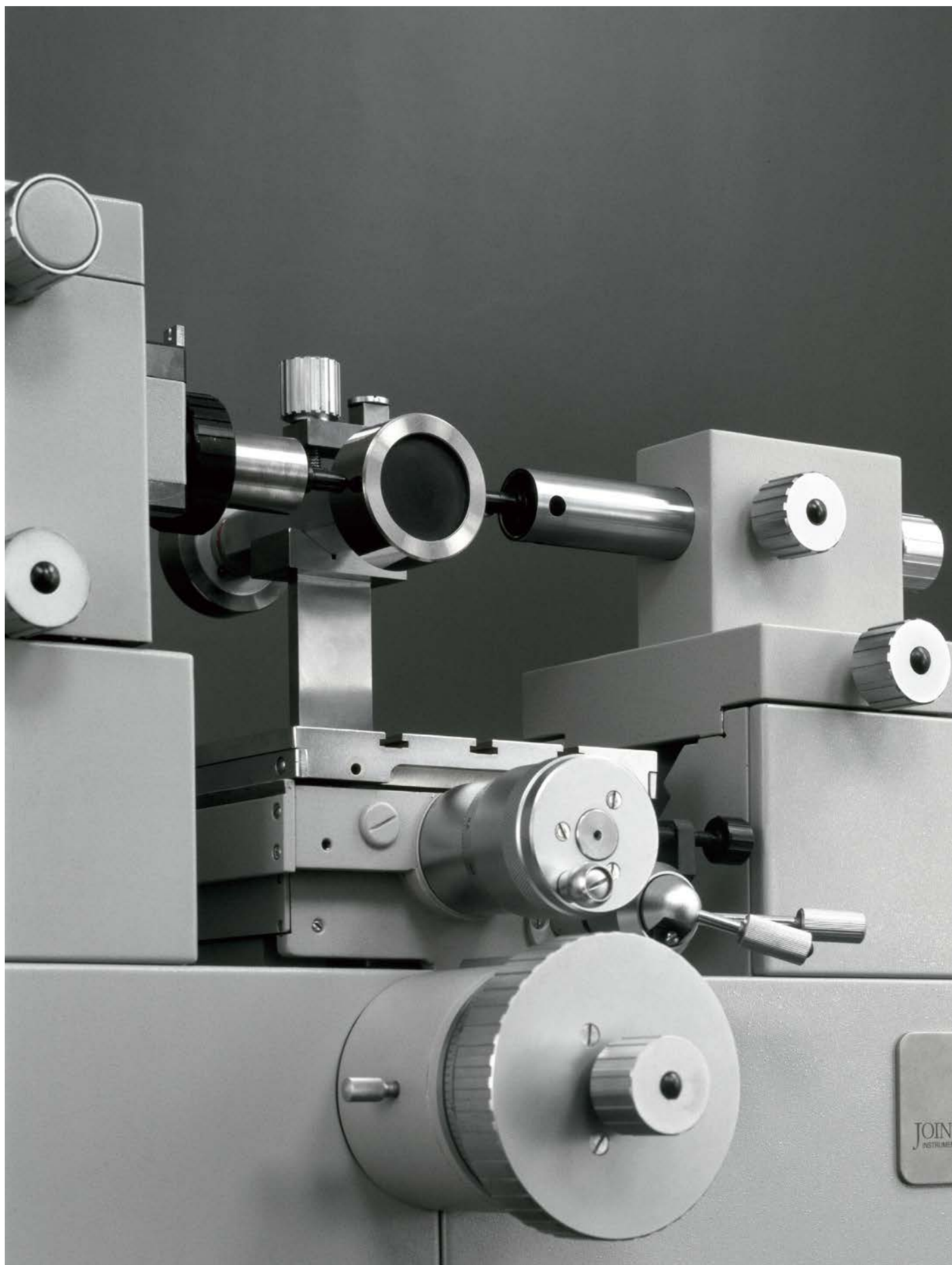

Universal length measuring system DMS 680

• Wide range of applications

For periodic inspection of gauges, reference gauges, masters and different gauges including :

- plug gauges
- ring gauges
- thread plug gauges
- thread ring gauges
- gauge blocks
- snap gauges
- external micrometers
- internal micrometers
- bore gauges
- dial indicators and electronic probes

• High precision

Obtained by:

- full compliance to Abbe's comparator principle
- constant measurement pressure
- adjustable work table for easy location of inversion point
- Heidenhain special glass scale
- PC direct reading with automatic detection of maximum and minimum value
- gauge calibration software guiding the operator through all measuring procedures
- automatic real time temperature compensation
- gauge management and measurement software

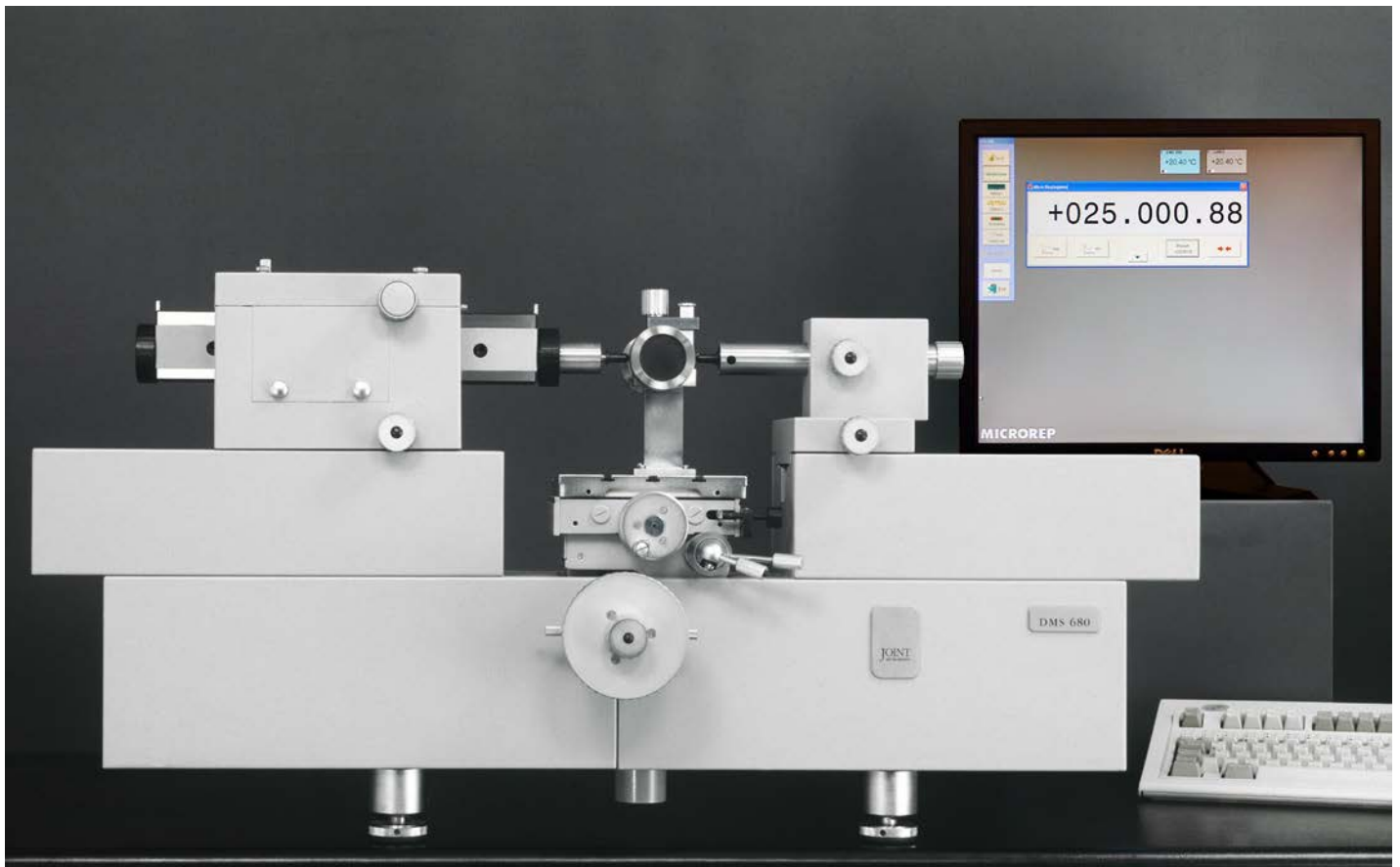

Gauge management and measurement software

The instrument is connected to a PC for direct reading of current value.

The software (included standard) provides a unique support for gauge management fulfilling norms requirements:

- the operator is fully guided through all measurement procedures
- automatic tolerances calculation is performed
- threads formulae are evaluated
- complete gauge records are provided including calibration date, location, cost centre, procedure and standard
- gauges can be sorted according to due date, type, department, cost centre and nominal dimension
- the procedure can be recalled and displayed during the measurement process
- master gauges are managed with last calibration date and automatic notification of due date
- provides full traceability of gauge history: each measurement is recorded with the operator, the master gauge, the machine and the equipment used for the inspection
- temperature compensation function

The screenshot displays the MICROREP software interface. On the left is a menu bar with options like 'Main Menu', 'Edit', 'View', 'Movements', and 'Measurement'. Below it is a toolbar with icons for 'SetUp', 'Gage', 'Instrument', 'New', 'Edit', and 'Find'. A table lists various gauges with columns for Code, Type, and Designation. The main window is titled 'Measurement - External plain' and shows a digital readout of '+022.998.7' mm. Above the display is a tolerance bar and a 'Go side' button. To the right is an 'Analogue' gauge graphic and temperature indicators showing '20.00 °C'. Below the main display are buttons for 'Read', 'Max', 'Min', and 'Clear', along with 'Normal', 'Min Dynamic', and 'Max Dynamic' selection options. At the bottom, a detailed table shows gauge history with columns for code, tolerance, diameter, date, and status.

Code	Type	Designation	Tolerance	Diameter	Date	Status	Location	Cost Center
55.BGJ.68	AL-P	50 mm						
CF.689.VT	TL-D	23 mm						
CR.567.VG	TF-D	M 45 X 2						
CT.766.BH	AL-P	60 mm						
CV.467.FG	TF-D	M 40 X 1.5						
DC.765.LH	AUTD	1 - 1/8 - 16 UN PD 1.0844						
DE.455.VG	TLNP	60 mm						
DF.532.DR	TL-D	22 mm						
DF.546.EF	TF-D	M 45 X 3						
DT.676.NY	FL-P	50 mm						
DT.855.GU	TL-D	63 mm						
ED.453.BG	BAF-P	1.000000-16.000000-BUT						
EE.546.FV	WAF-NP	1 1/4 in - 9 BSF (Medium)						
EG.654.HN	GS-AC	Rc 1 1/4						
ET.657.NH	TL-D	55 mm						
FC.980.YH	AUTD	2 - 3/8 - 20 UN PD 2.3425						
FE.657.XZ	FL-P	79 mm						
FH.577.BH	TL-D	37 mm						
FR.436.VG	GS-AF	Rp 1 1/2						
FR.456.BG	AUTD	1 - 7/16 - 18 UNEF PD 1.4						
FR.646. BH	FLCD	46 mm	+046.000.0	0	06/06/2009	n8	In use	
FR.680.BT	FL-P	54 mm	+054.000.0	0	27/02/2009	J7	In use	3541356
GB.566. DS	WTF-D	9/16 in - 12 BSW (Medium)	+014.287.5	+002.116.6	55	08/05/2009	Medium	In use 3541356
GF.543.FD	TF-D	M 35 X 1	+035.000.0	+001.000.0	60	06/02/2010	7H	In use 3541356
GH.688.BY	WAF-NP	9/32 in - 26 BSF (Close)	+007.143.9	+000.977.0	55	07/10/2008	Close	In use
GT.678.FG	WAF-NP	5/8 in - 14 BSF (Free)	+015.875.0	+001.814.1	55	23/01/2009	Free	In use
GT.746.HT	AUAN	0 - 7/16 - 32 UN PD 0.417202	+010.596.9	+000.793.9	60	19/07/2010	2A	In use
HY.686.TG	AF-P	M 50 X 2	+050.000.0	+002.000.0	60	07/02/2009	6h	In use 3541356
RF.688.GB	TL-D	43 mm	+043.000.0	0	05/01/2009	H6	In use	8776324
TG.674.GF	TL-D	10 mm	+010.000.0	0	13/03/2009	H8	In use	
TR.674.NU	TL-D	7 mm	+007.000.0	0	13/03/2009	H8	In use	
VH.678.BY	TL-P	25 mm	+025.000.0	0	14/03/2009	H7	In use	8776324
VT.664.HT	TL-D	35 mm	+035.000.0	0	07/03/2009	H8	In use	3541356
XC.346.TH	AUTD	1 - 13/16 - 12 UN PD 1.758373	+044.662.7	+002.116.6	60	28/02/2009	3B	In use
ZD.688.YT	NPTT	1 1/2 11.5 NPT	+048.260.0	+002.208.7	60	06/01/2009		In use

Plug gauge measurement: the movement of the work table enable high speed location of the inversion point



Thread gauge measurement: three wire method

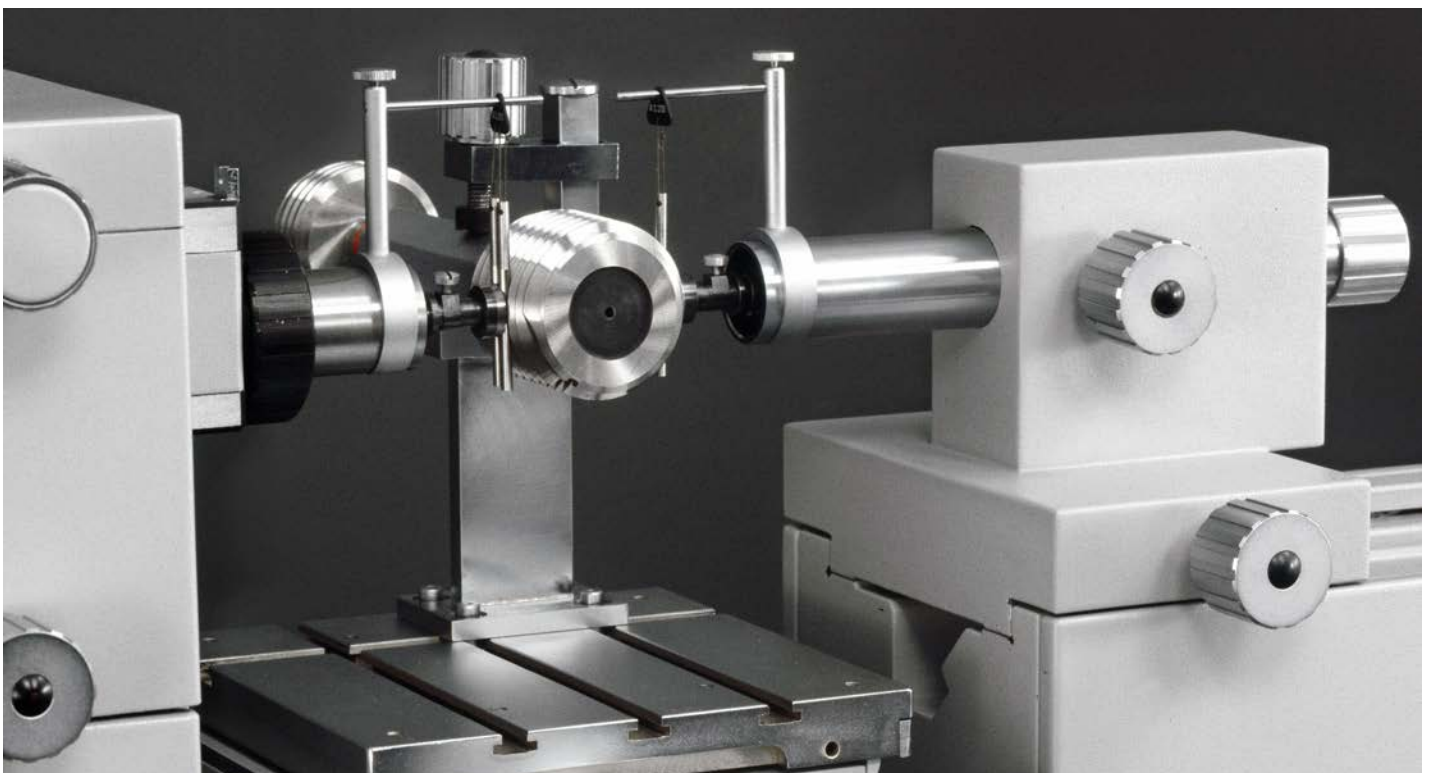

Gauge block checking: the inspection is carried out by comparison with master gauge block



Internal micrometer measurement

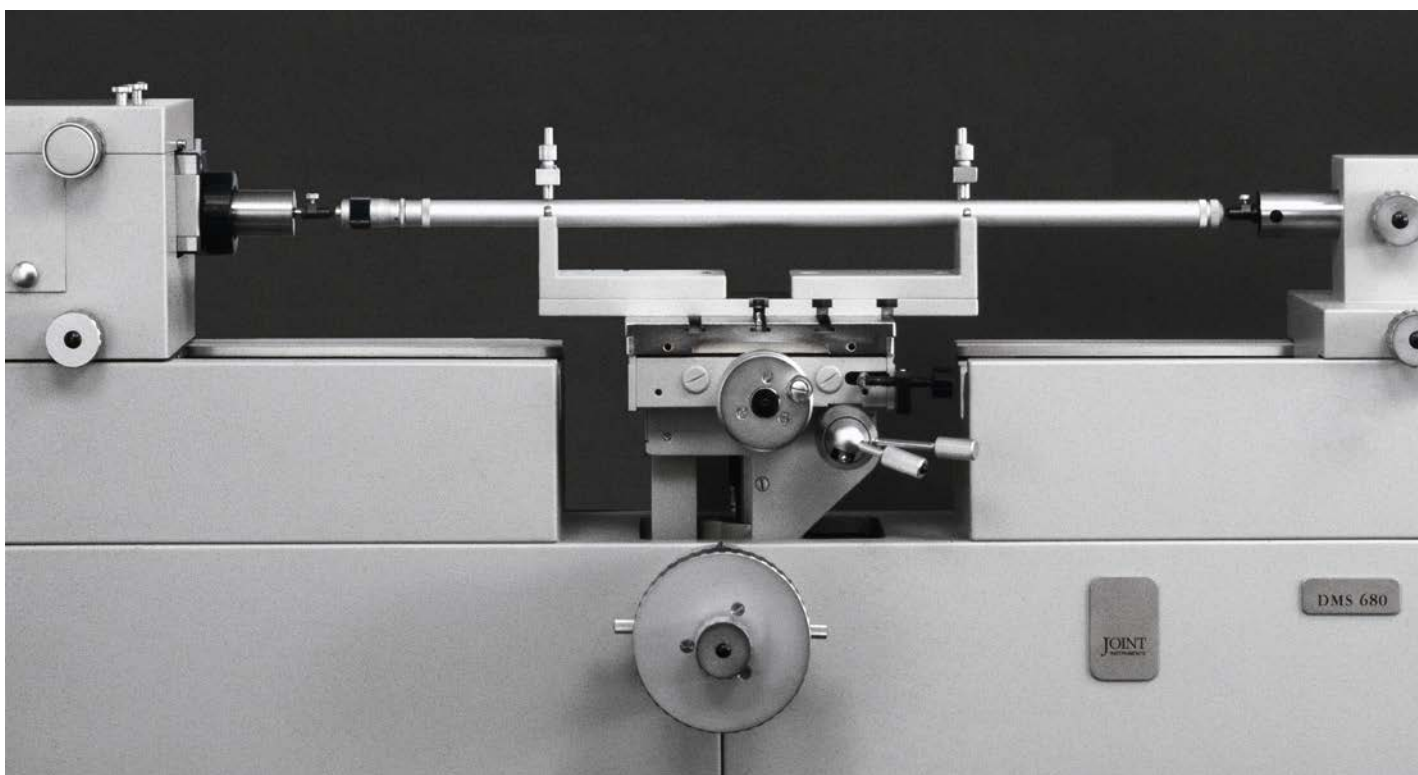

Ring gauge measurement

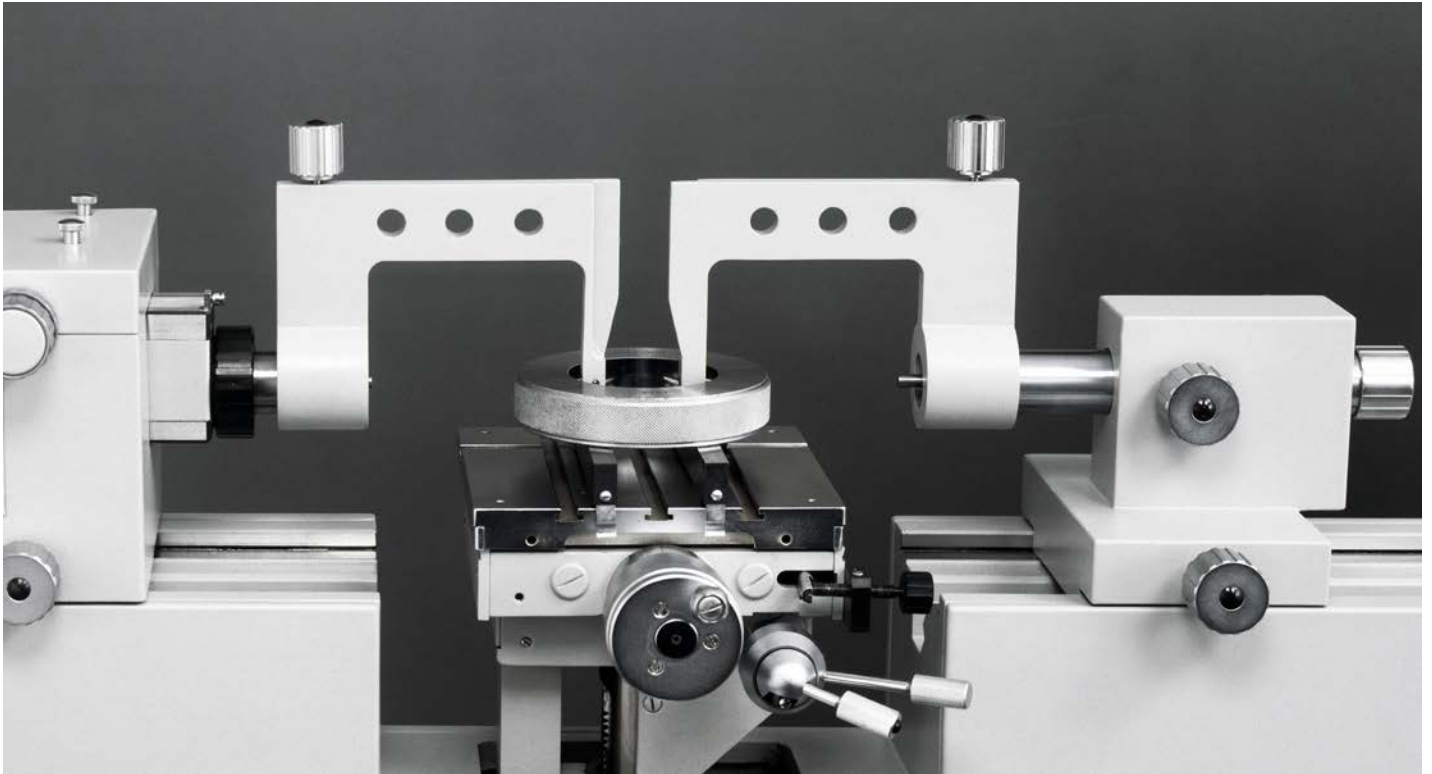

Thread ring gauge measurement: a pair of large contact arms and small contact arms, together with 11 pairs of spheres, are used to measure thread ring gauges



Small hole measurement device: the measurement is carried out with zero contact force

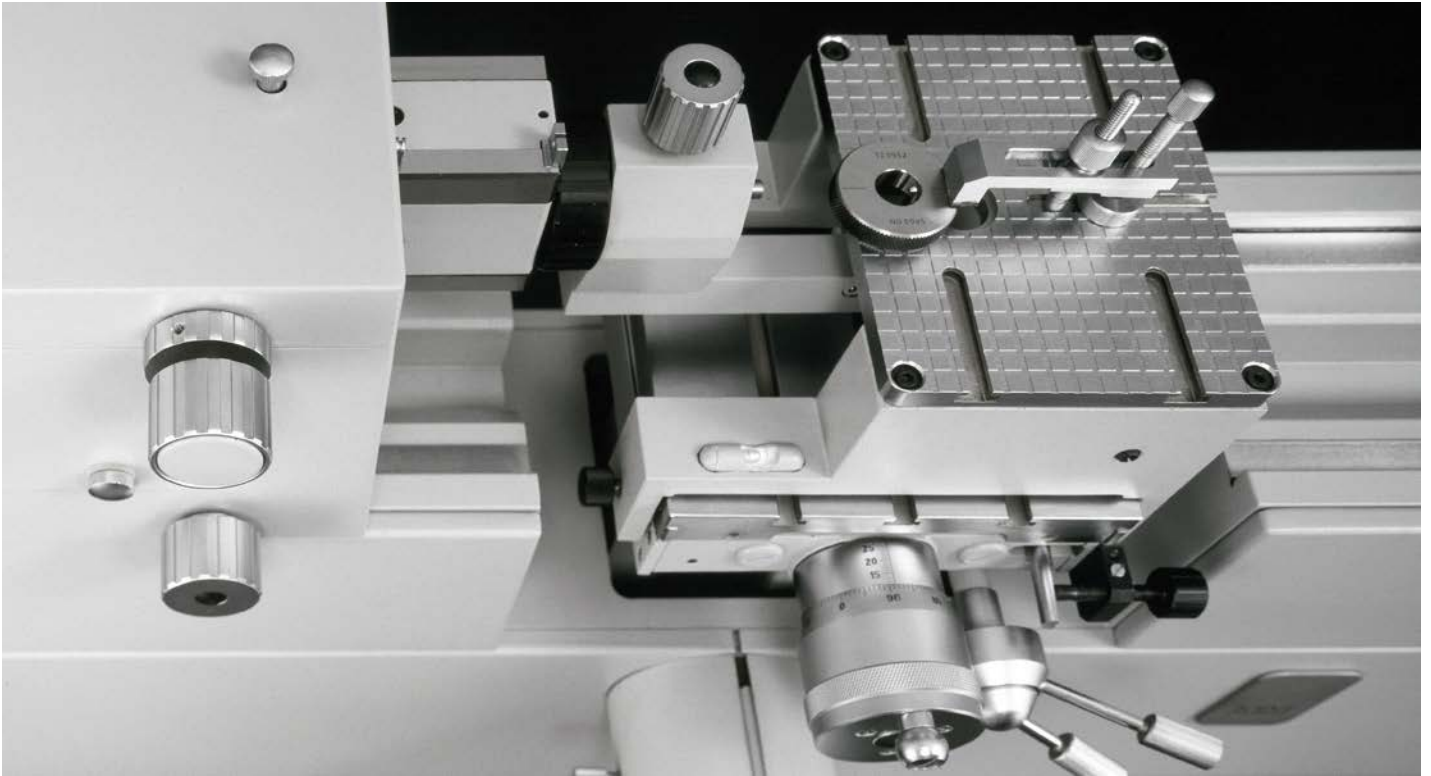

Plug gauge measurement

Snap gauge measurement

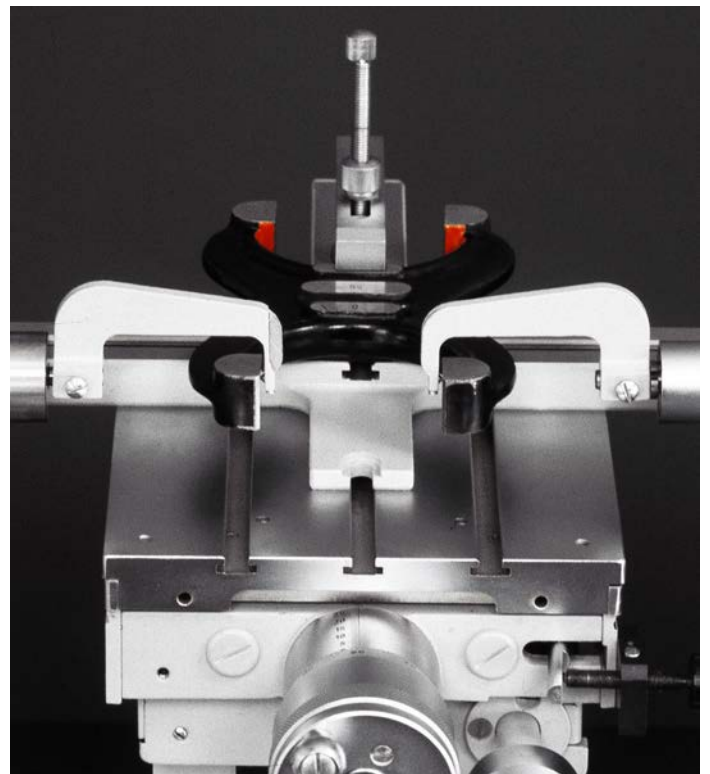
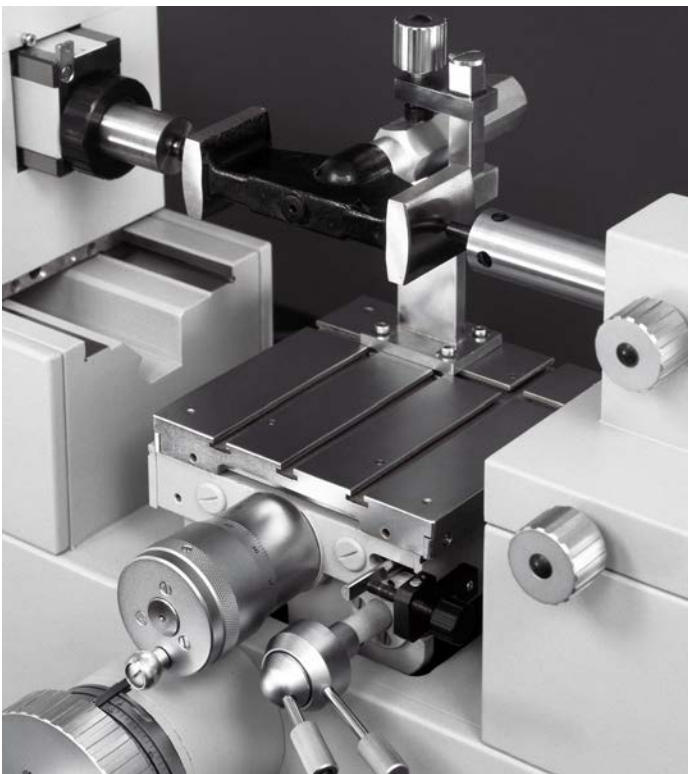

External micrometer inspection

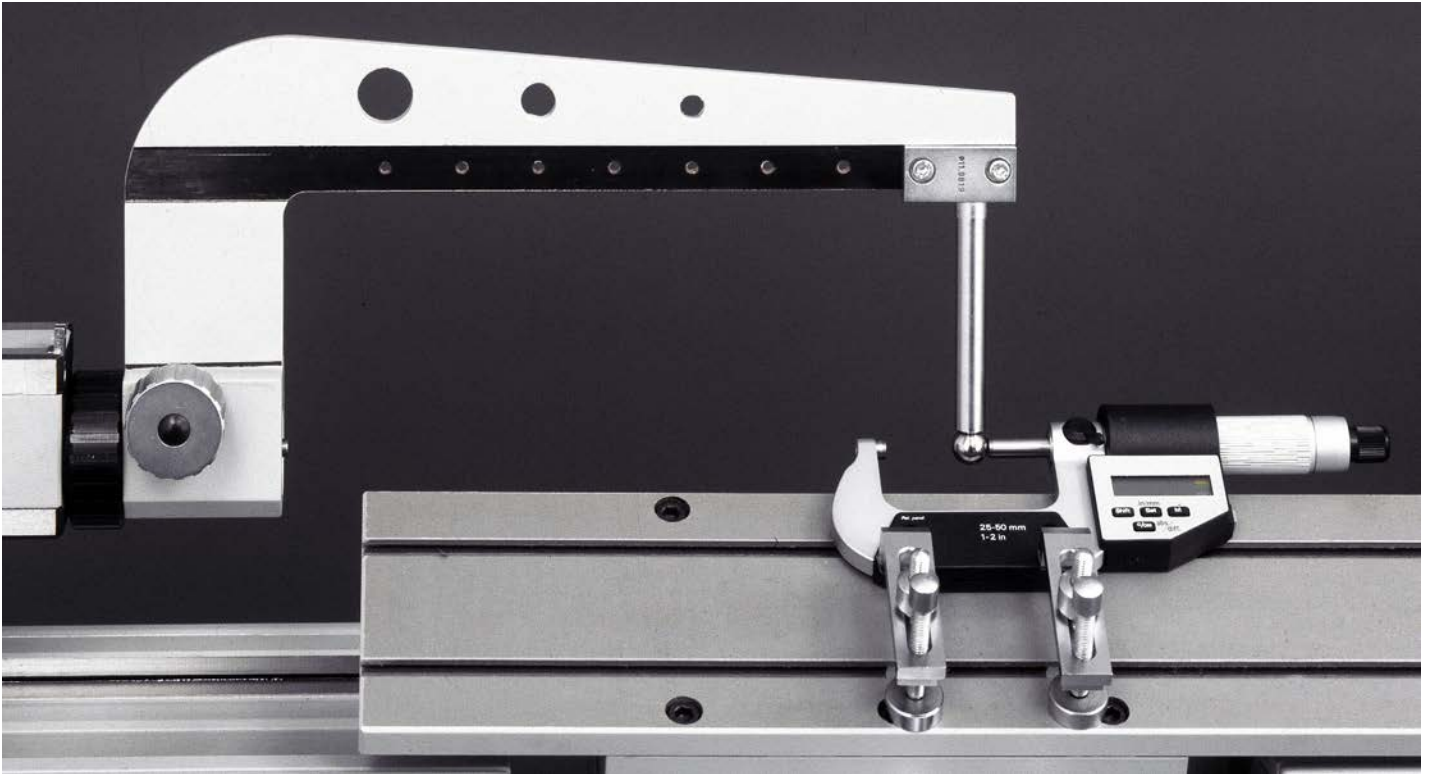

Dial indication inspection



SPECIFICATIONS

Range of Applications (diameters from - to)		
external plain:	0 - 680 mm	0 - 27"
internal plain:	1 - 480 mm	0.04 - 19"
external thread:	0 - 480 mm	0 - 19"
internal thread:	3 - 400 mm	0.12 - 16"
Measuring Range		
absolute:	100 mm	4"
differential:	680 mm 1000 mm	27" 40"
Size and Weight		
load capacity:	11 Kg	25 Ib
dimensions:	1300 x 400 x 480 mm	51 x 16 x 19"
weight:	110 Kg	240 Ib
measuring force:	0-11 N	0-2.5 lb
Resolution (mm/inch switchable)		
DMS 680 standard	0.1 µm	0.000005"
DMS 680 S e HA	0.01 µm	0.000001"
Accuracy (MPE _{E1})		
DMS 680 standard	$0.18 + \frac{L_{(mm)}}{1200}$ µm	0.000010"
DMS 680 S	$0.14 + \frac{L_{(mm)}}{1200}$ µm	0.000008"
DMS 680 HA	$0.10 + \frac{L_{(mm)}}{2000}$ µm	0.000006"

STANDARD EQUIPMENT - included

Work table

adjustable in all directions:
vertical, horizontal, work top rotation and tilting

Reading unit

PC, LCD flat monitor and Heidenhain pc board
on line reading software including:
direct reading of current measurement value
analogue readout for inversion point location
automatic detection of maximum and minimum value
statistical function
zero setting and preset

Plug gauge measurement device

clamping device for plug gauge
contact tips rounded and knife edge

Ring gauge measurement device

small contact arms
large contact arms
special tailstock spindle
rounded contact tips
precision setting rings with 14 and 50 mm diameter

Small hole measurement device

special table
contact spheres with diameter of 0.8 and 3 mm

Thread plug gauge measurement device

set of calibrated wires from 0.335 to 6.35 mm (other diam. on request)
flat contact tips with 8 and 14 mm diameter

Thread ring gauge measurement device

for inside threads with diameter from 14 to 90 mm
precision contact spheres with diameter of 0.8 - 1.35 - 1.8 - 2.3 - 3.1 mm
floating table

Snap gauge measurement device

clamping plate for snap gauge
clamping devices

External micrometer measurement device

micrometer holder
contact arm with contact tips

Internal micrometer measuring device

double side "V" bearing

Dial indicator measurement device

clamping device

Centre cradle

distance between centers 200 mm
maximum piece diameter 180 mm

Gauge management & measurement software

gauge management and measurement modules
automatic tolerance calculation
measurement procedures and thread formulae included

Temperature compensation device

direct reading and compensation of the DMS 680 temperature
with 0.01°C | 0.01°F resolution

OPTIONAL EQUIPMENT

T-sphere thread ring gauge measurement device

for inside threads with diameter down to 3 mm
floating measuring device with inductive lever probe
analogue readout for inversion
set of 8 pairs of T spheres from 0.3 to 1.3 mm
(other spheres available on request)

Pitch measurement device

for internal and external threads

Big thread ring gauge measurement device

for inside threads with diameter from 90 to 400 mm

Extra weight system

to increase measuring force from 2.5 N to 11 N

Pipe thread measurement device

for inside and outside taper thread
allows to determine the height of measurement

1000 mm extension

special casted extensions to increase external measurement capacity up to 1000 mm | 40"



a brand-name of Microrep

MICROREP

PIAZZA S.AMBROGIO 12 - 20090 SEGRATE - MILANO - ITALY - PHONE +39.02.2139.580 - FAX +39.02.2139.595
WWW.MICROREP.IT

